

Air conditioner

User & installation manual

AC***BNPDKC / AC***BXPD*C

- Thank you for purchasing this Samsung air conditioner.
- Before operating this unit, please read this manual carefully and retain it for future reference.



SAMSUNG

Contents

Safety Information	4
Safety Information	4
Operation Features	9
Checking auxiliary power switch • Operating temperature and humidity	9
At a Glance	10
Indoor Unit Overview	10
Control Panel Overview	12
Indoor unit display	12
Controlling with the control panel	13
Turning on or off the air conditioner • Controlling temperature • Controlling the fan speed	13
Selecting the operation mode/Locking the control panel	14
Remote Control Overview	15
Replacing batteries • Storing the remote control	16
Remote Control Operation	17
Turning on or off the air conditioner • Operation modes	17
Controlling fan speed • Controlling temperature • Controlling air flow direction	18
Power Smart Features	19
Power Smart Features	19
Auto mode • Cool mode	19
Dry mode • Fan mode	20
Variety Smart Features	21
Turbo function • Long reach function	21
Clean function	22
Energy-Saving Operation	23
Timed on/Timed off function	23
Cleaning and Maintenance	24
Cleaning at a Glance	24
Cleaning the indoor unit exterior and outdoor unit heat exterior	24
Cleaning the filter	25
Periodical maintenance	26
Troubleshooting	27

Safety Information	29
Safety Information (Installing the Air Conditioner)	29
General information	29
Installing the unit	30
Power supply line, fuse or circuit breaker	30
Installation Procedure	32
Step 1 Choosing the installation location	32
Step 2 Unpacking	36
Step 3 Checking and preparing accessories	36
Step 4 Drilling a hole through a wall	37
Step 5 Taping the pipes, cables, and drain hose	37
Step 6 Purging inert gas from the indoor unit	38
Step 7 Optional: Cutting and flaring the pipes	38
Step 8 Connecting the refrigerant pipes	39
Step 9 Connecting the power and communication cables	41
Step 10 Optional: Extending the power cable	44
Step 11 Checking the earthing	46
Step 12 Performing gas leakage test	46
Step 13 Evacuating the air	47
Step 14 Charging the refrigerant	47
Step 15 Fixing and insulating the connection part for refrigerant pipes	48
Step 16 Installing and connecting the drain hose	49
Step 17 Performing drainage test	50
Step 18 Checking the earthing	50
Step 19 Performing the final check and trial operation	51
Appendix	56
Troubleshooting	56



***Correct Disposal of This Product
(Waste Electrical & Electronic Equipment)***

(Applicable in countries with separate collection systems)

This marking on the product, accessories or literature indicates that the product and its electronic accessories (e.g. charger, headset, USB cable) should not be disposed of with other household waste at the end of their working life. To prevent possible harm to the environment or human health from uncontrolled waste disposal, please separate these items from other types of waste and recycle them responsibly to promote the sustainable reuse of material resources.

Household users should contact either the retailer where they purchased this product, or their local government office, for details of where and how they can take these items for environmentally safe recycling. Business users should contact their supplier and check the terms and conditions of the purchase contract. This product and its electronic accessories should not be mixed with other commercial wastes for disposal.

Safety Information

Before using your new air conditioner, please read this manual thoroughly to ensure that you know how to safely and efficiently operate the extensive features and functions of your new appliance.

Because the following operating instructions cover various models, the characteristics of your air conditioner may differ slightly from those described in this manual. If you have any questions, call your nearest contact center or find help and information online at www.samsung.com.

These warning signs are here to prevent injury to you and others. Please follow them carefully.

Important safety symbols and precautions:



WARNING

Hazards or unsafe practices that may result in severe personal injury or death.



CAUTION

Hazards or unsafe practices that may result in minor personal injury or property damage.



Follow directions.



Do NOT attempt.



Make sure the machine is grounded to prevent electric shock.



Cut-off the power supply.



Do NOT disassemble.

FOR INSTALLATION



WARNING



Use the power line with the power specifications of the product or higher and use the power line for this appliance only. In addition, do not use an extension line.

- Extending the power line may result in electric shock or fire.
- Do not use an electric transformer. It may result in electric shock or fire.
- If the voltage/frequency/rated current condition is different, it may cause fire.

The installation of this appliance must be performed by a qualified technician or service company.

- Failing to do so may result in electric shock, fire, explosion, problems with the product, or injury.

Install a switch and circuit breaker dedicated to the air conditioner.

- Failing to do so may result in electric shock or fire.

Fix the outdoor unit firmly so that the electric part of the outdoor unit is not exposed.

- Failing to do so may result in electric shock or fire.

 Do not install this appliance near a heater, inflammable material. Do not install this appliance in a humid, oily or dusty location, in a location exposed to direct sunlight and water (rain drops). Do not install this appliance in a location where gas may leak.

- This may result in electric shock or fire.

Never install the outdoor unit in a location such as on a high external wall where it could fall.

- If the outdoor unit falls, it may result in injury, death or property damage.

 This appliance must be properly grounded. Do not ground the appliance to a gas pipe, plastic water pipe, or telephone line.

- Failure to do so may result in electric shock, fire, an explosion, or other problems with the product.



CAUTION

 Install your appliance on a level and hard floor that can support its weight.

- Failing to do so may result in abnormal vibrations, noise, or problems with the product.

Install the draining hose properly so that water is drained correctly.

- Failing to do so may result in water overflowing and property damage.

When installing the outdoor unit, make sure to connect the draining hose so that draining is performed correctly.

- The water generated during the heating operation by the outdoor unit may overflow and result in property damage. In particular, in winter, if a block of ice falls, it may result in injury, death or property damage.

Do not install the product in a place where thermo-hygrostat is needed (such as server room, machinery room, computer room, etc.)

- Those places do not provide guaranteed operation condition of the product therefore performance can be poor in these places.

Do not install the product in a place where hair spray is frequently used (such as hair salon) since it decreases the hydrophilicity of the product's heat exchanger and cause dew formation on the surface of the product.

FOR POWER SUPPLY



WARNING

 When the circuit breaker is damaged, contact your nearest service centre.

 Do not pull or excessively bend the power line. Do not twist or tie the power line. Do not hook the power line over a metal object, place a heavy object on the power line, insert the power line between objects, or push the power line into the space behind the appliance.

- This may result in electric shock or fire.



CAUTION

 When not using the air conditioner for a long period of time or during a thunder/lightning storm, cut the power at the circuit breaker.

- Failing to do so may result in electric shock or fire.

Safety Information

FOR USING



WARNING



If the appliance is flooded, please contact your nearest service centre.

- Failing to do so may result in electric shock or fire.

If the appliance generates a strange noise, a burning smell or smoke, cut-off the power supply immediately and contact the nearest service center.

- Failing to do so may result in electric shock or fire.

In the event of a gas leak (such as propane gas, LP gas, etc.), ventilate immediately without touching the power line. Do not touch the appliance or power line.

- Do not use a ventilating fan.
- A spark may result in an explosion or fire.

To reinstall the air conditioner, please contact your nearest service centre.

- Failing to do so may result in problems with the product, water leakage, electric shock, or fire.
- A delivery service for the product is not provided. If you reinstall the product in another location, additional construction expenses and an installation fee will be charged.
- Especially, when you wish to install the product in an unusual location such as in an industrial area or near the seaside where it is exposed to the salt in the air, please contact your nearest service centre.



Do not touch the circuit breaker with wet hands.

- This may result in electric shock.

Do not strike or pull the air conditioner with excessive force.

- This may result in fire, injury, or problems with the product.

Do not place an object near the outdoor unit that allows children to climb onto the machine.

- This may result in children seriously injuring themselves.

Do not turn the air conditioner off with the circuit breaker while it is operating.

- Turning the air conditioner off and then on again with the circuit breaker may cause a spark and result in electric shock or fire.

After unpacking the air conditioner, keep all packaging materials well out of the reach of children, as packaging materials can be dangerous to children.

- If a child places a bag over its head, it may result in suffocation.

Do not insert your fingers or foreign substances into the outlet when the air conditioner is operating or the air flow blade is closing.

- Take special care that children do not injure themselves by inserting their fingers into the product.

Do not insert your fingers or foreign substances into the air inlet/outlet of the air conditioner.

- Take special care that children do not injure themselves by inserting their fingers into the product.

Do not use this air conditioner for long periods of time in badly ventilated locations or near infirm people.

- Since this may be dangerous due to a lack of oxygen, open a window at least once an hour.

 If any foreign substance such as water has entered the appliance, cut-off the power supply and contact the nearest service center.

- Failing to do so may result in electric shock or fire.

 Do not attempt to repair, disassemble, or modify the appliance yourself.

- Do not use any fuse (such as copper, steel wire, etc.) other than the standard fuse.
- Failing to do so may result in electric shock, fire, problems with the product, or injury.

CAUTION

 Do not place objects or devices under the indoor unit.

- Water dripping from the indoor unit may result in fire or property damage.

Check that the installation frame of the outdoor unit is not broken at least once a year.

- Failing to do so may result in injury, death or property damage.

Max current is measured according to IEC standard for safety and current is measured according to ISO standard for energy efficiency.

 Do not stand on top of the appliance or place objects (such as laundry, lighted candles, lighted cigarettes, dishes, chemicals, metal objects, etc.) on the appliance.

- This may result in electric shock, fire, problems with the product, or injury.

Do not operate the appliance with wet hands.

- This may result in electric shock.

Do not spray volatile material such as insecticide onto the surface of the appliance.

- As well as being harmful to humans, it may also result in electric shock, fire or problems with the product.

Do not drink the water from the air conditioner.

- The water may be harmful to humans.

Do not apply a strong impact to the remote control and do not disassemble the remote control.

Do not touch the pipes connected with the product.

- This may result in burns or injury.

Do not use this air conditioner to preserve precision equipment, food, animals, plants or cosmetics, or for any other unusual purposes.

- This may result in property damage.

Avoid directly exposing humans, animals or plants from the air flow from the air conditioner for long periods of time.

- This may result in harm to humans, animals or plants.

This appliance is not intended for use by persons (including children) with reduced physical, sensory or mental capabilities, or lack of experience and knowledge, unless they have been given supervision or instruction concerning use of the appliance by a person responsible for their safety. Children should be supervised to ensure that they do not play with the appliance.

Safety Information

FOR CLEANING



WARNING



Do not clean the appliance by spraying water directly onto it. Do not use benzene, thinner, alcohol or acetone to clean the appliance.

- This may result in discoloration, deformation, damage, electric shock or fire.

Before cleaning or performing maintenance, cut-off the power supply and wait until the fan stops.

- Failing to do so may result in electric shock or fire.



CAUTION



Take care when cleaning the surface of the heat exchanger of the outdoor unit since it has sharp edges.

- To avoid cutting your fingers, wear thick cotton gloves when cleaning it.



Do not clean the inside of the air conditioner by yourself.

- For cleaning inside the appliance, contact your nearest service centre.
- When cleaning the internal filter, refer to the descriptions in the 'Cleaning and maintaining the air conditioner' section.
- Failure to do so may result in damage, electric shock or fire.

Operation Features

Checking auxiliary power switch

1 phase circuit breaker



3 phase 4 wire circuit breaker

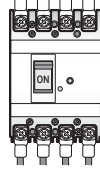

Turn on the auxiliary power switch which is installed separately.

NOTE

Auxiliary power switch(ELCB, ELB)

- Auxiliary power switch is not included in the package. Purchase and install it separately.
- Auxiliary power switch is a device for preventing over-current or short circuit. Turn off the auxiliary power switch when you are cleaning the product or not going to use the product for long period of time.
- If ELB has already been installed in the switch box of the building, it is not mandatory for you to install the auxiliary power switch.

Operating temperature and humidity

Mode	Outdoor temperature	Indoor temperature	Indoor humidity
Cool mode	-15°C to 54°C	18°C to 32°C	80% or less
Dry mode	-15°C to 54°C	18°C to 32°C	80% or less

CAUTION

- If you use the air conditioner at a relative humidity above 80%, it may cause a formation of condensation and a leakage of water on the floor.
- If the indoor unit is out of the operating temperature and humidity range, the safety device may operate and the air conditioner may stop.

Indoor Unit Overview

The actual product may differ slightly from the image depicted below.

AC030BNPDKC

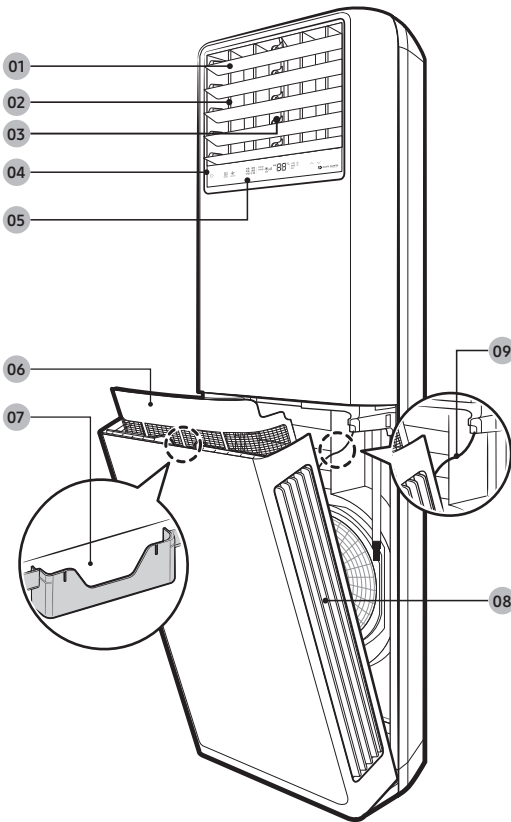

- 01 Air flow blade (up and down)
- 02 Air flow blade (left and right)
- 03 Air outlet
- 04 Control panel
- 05 Indoor unit display
- 06 Air filter
- 07 Remote control holder
- 08 Air intake
- 09 Safety hook

At a Glance

Opening the panel

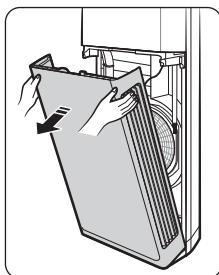

Hold the upper part of the panel, then pull it slightly forward.

CAUTION

- Do not open the panel when the air conditioner is operating. It may cause a malfunction or an electric shock.

NOTE

- Be sure to fasten the safety hook on the panel while in operation.

AC036/048/054BNPDKC

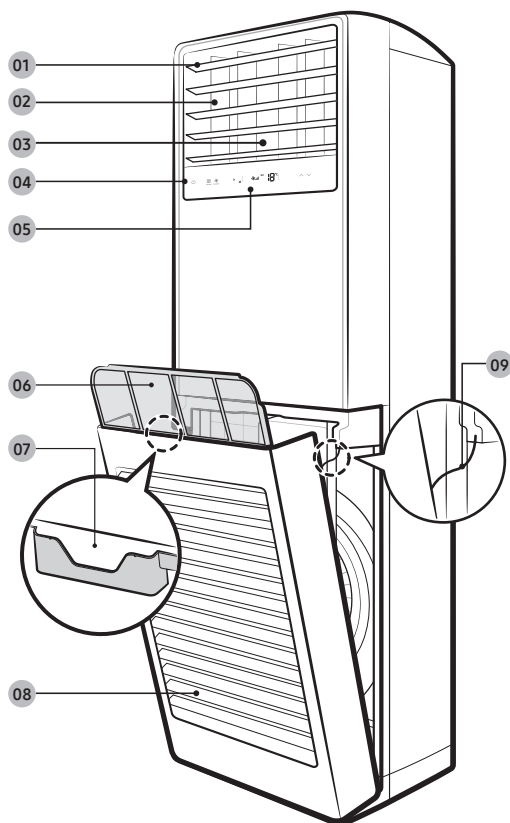

- 01 Air flow blade (up and down)
- 02 Air flow blade (left and right)
- 03 Air outlet
- 04 Control panel
- 05 Indoor unit display
- 06 Air filter
- 07 Remote control holder
- 08 Air intake
- 09 Safety hook

Opening the panel

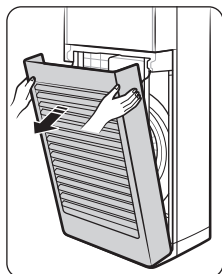

Hold the upper part of the panel, then pull it slightly forward.

CAUTION

- Do not open the panel when the air conditioner is operating. It may cause a malfunction or an electric shock.

NOTE

- Be sure to fasten the safety hook on the panel while in operation.

Control Panel Overview

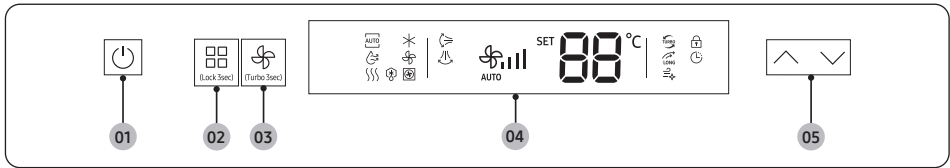

- 01 Power button
- 02 Mode button (Lock button)
- 03 Fan speed button (Turbo function Button)
- 04 Indoor unit display
- 05 Temperature button

Indoor unit display

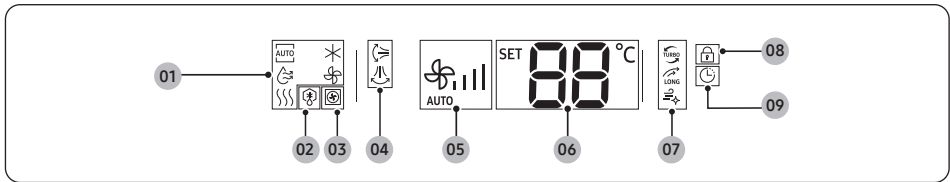

- 01 Operation mode indicators
- 02 Defrost operation indicator
- 03 Outdoor unit operation indicator
- 04 Vertical air swing indicator / Horizontal air swing indicator
- 05 Fan speed indicator
- 06 Set temperature indicator
- 07 Turbo function indicator / Long reach function indicator / Clean function indicator /
- 08 Lock indicator
- 09 Set timer indicator

NOTE

- The Heat mode is not supported by this model.

NOTE



- If you set a dedicated mode available only in the upper level controller (DMS), it may limit available operation modes that can be selected in the indoor unit display.
 - DMS cooling mode: Auto, Cool, Dry, and Fan

Controlling with the control panel

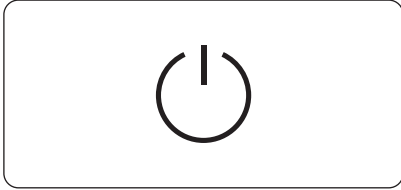
You can control the air conditioner with the control panel without using the remote control.



Turning on or off the air conditioner

Press the  (Power) button. The air conditioner turns on with a ring sound and then its operation starts. To turn off the air conditioner, press the  (Power) button again.

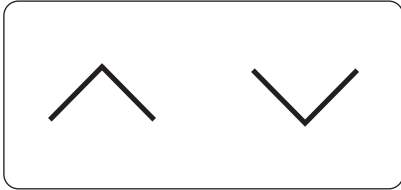

Controlling temperature





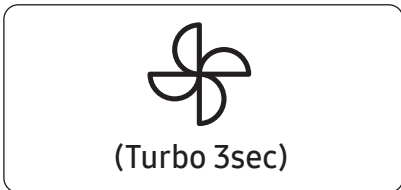



Each time you press the button, the temperature increases or decreases by 1 °C.

Mode	Temperature control
Auto/Cool/Dry	Adjust by 1°C between 18°C and 30°C.
Fan	You cannot control the temperature.



Controlling the fan speed

Press the  (Fan speed) button to change the fan speed in each mode. Each time you press the button, the fan speed changes in the following order:

Mode	Available fan speeds
Auto/Dry	 AUTO (Auto)
Cool	 (Med),  (High),  (Turbo),  AUTO (Auto),
Fan	 (Med),  (High),  (Turbo)

Press and hold the  (Fan speed) button for 3 seconds to activate the Turbo function.



NOTE

- In Fan mode, cool air does not come out because the outdoor unit does not operate.

Controlling with the control panel



Selecting the operation mode/ Locking the control panel

- Press the  (Mode) button to change the operation mode. Each time you press the button, the mode changes in the following order: Auto → Cool → Dry → Fan.
- Press the  (Mode) button for 3 seconds. The  (Lock) indicator appears and then the control panel is locked with a ring sound.

NOTE

- Once the Lock function has been activated, the air conditioner cannot be controlled with the control panel but the remote control.
- To release the Lock function, press the  (Mode) button for 3 seconds.

Remote Control Overview

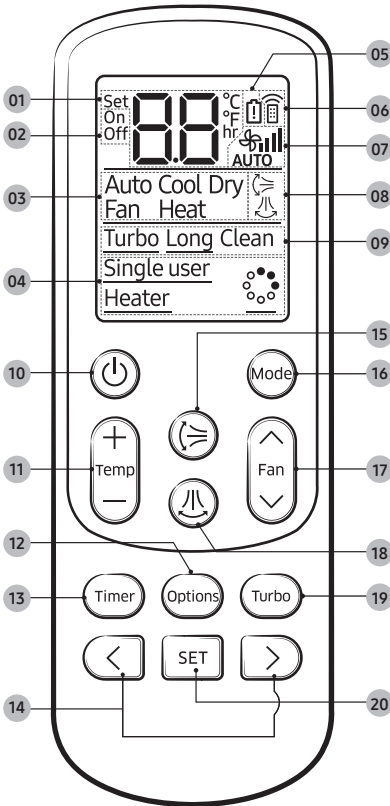

- 01 Set temperature indicator
- 02 Timed on/off indicator
- 03 Operation mode indicator

NOTE

- The Heat mode is not supported by this model.

- 04 Unsupported functions

NOTE

- The Single user, Heater and Purity functions () are not supported by this model.

- 05 Low battery indicator
- 06 Signal transmission indicator
- 07 Fan speed indicator
- 08 Vertical air swing indicator / Horizontal air swing indicator
- 09 Options indicator
- 10 Power button
- 11 Temperature button
- 12 Options button
- 13 Timer button
- 14 Direction button / Selection button
- 15 Vertical air swing button
- 16 Mode button
- 17 Fan speed button
- 18 Horizontal air swing button
- 19 Turbo button
- 20 SET button

NOTE

- The descriptions in this manual are primarily made based on the remote control buttons.
- When you press the button, a short ring will sound and a transmit indicator () appears on the remote controller display.
- Remote controller will remember the most recent temperature setting if you turn off the air conditioner and then turn it on again.

Remote Control Overview

Replacing batteries

When the  icon appears in the remote control display, replace the batteries with new ones. Two 1.5V AAA type batteries are required.

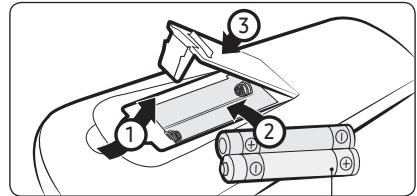

Two 1.5V AAA type batteries



Correct disposal of batteries in this product

This marking on the battery, manual or packaging indicates that the batteries in this product should not be disposed of with other household waste at the end of their working life. Where marked, the chemical symbols Hg, Cd or Pb indicate that the battery contains mercury, cadmium or lead above the reference levels in EC Directive 2006/66.

Storing the remote control

If the remote control will not be used for an extended period of time, remove the batteries and store it in a remote control holder on the wall or inside the panel.



CAUTION

- Make sure that water does not come into the remote control.

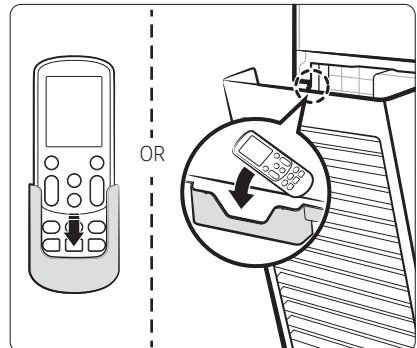

Remote Control Operation

You can use the air conditioner easily by selecting a mode or function and then by controlling the temperature, fan speed, and air flow direction.

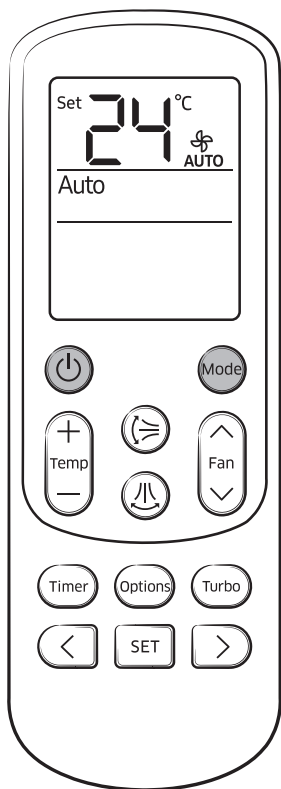

Turning on or off the air conditioner

You can turn on or off the air conditioner by pressing the  (Power) button.

Operation modes

You can change the current mode between Auto, Cool, Dry, Fan and Heat by pressing the  (Mode) button.

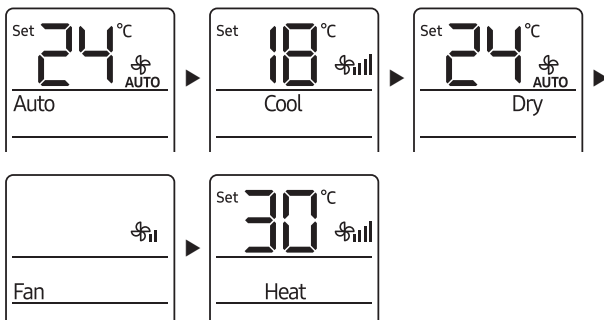

NOTE

- The Heat mode is not supported by this model.

Remote Control Operation



Controlling fan speed

You can select the following fan speeds in each mode:

Mode	Available fan speeds
Auto/Dry	AUTO (Auto)
Cool	AUTO (Auto), II (Med), III (High), IIII (Turbo)
Fan	II (Med), III (High), IIII (Turbo)

Controlling temperature

You can control the temperature in each mode as follows:

Mode	Temperature control
Auto/Cool/Dry	Adjust by 1°C (1°F) between 18°C (65°F) and 30°C (86°F)
Fan	You cannot control the temperature.

You can switch between Celsius and Fahrenheit indications on the remote control.

► Press and hold for 3 or more seconds.

NOTE

- The temperature indications on the indoor unit are not switched.
- This function is canceled when the remote control batteries are replaced. In this case, run this function again.

Controlling air flow direction

This function allows you to shift the air flow direction up and down or left and right.

In operation ► or

- Press the or button to move the air flow direction up and down or left and right while the air conditioner is turned on.
- When the blade reaches the desired position, press the or button one more time to set the air flow direction. The up/down and left/right tilting of the blade will stop.

Power Smart Features

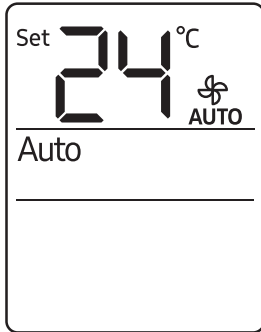

Auto mode

Use the Auto mode when you want the air conditioner to automatically control the Cool mode. The air conditioner will provide the most comfortable atmosphere that it can.



NOTE

- You cannot change the fan speed.
- While the Cool mode is running, the air conditioner produces a strong cold air if there is a large difference between the set temperature and the current temperature. When the temperature difference becomes small, the air conditioner automatically changes the air flow direction to Wide and keeps the room at a comfortable temperature.

Cool mode

Use the Cool mode to stay cool in hot weather.



NOTE

- For comfort, keep the temperature difference between the indoor and outdoor air within 5°C (9°F) in the Cool mode.
- To cool your room quickly, select a low temperature and a high fan speed.
- To save energy, select a high temperature and a low fan speed.
- As the indoor temperature approaches the set temperature, the compressor will operate at a low speed to save energy.

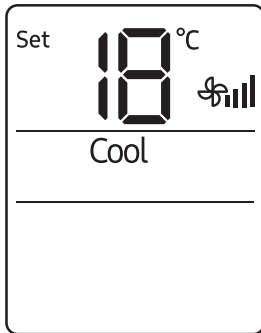

Power Smart Features

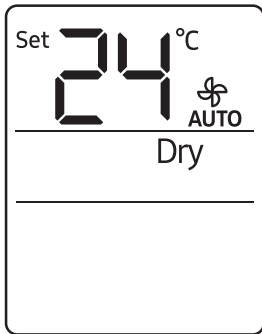

Dry mode

Use the Dry mode in rainy or humid weather.



NOTE

- You cannot change fan speed in the Dry mode.
- The greater the difference between the set temperature and the current temperature is, the greater the amount of air that is dehumidified is.

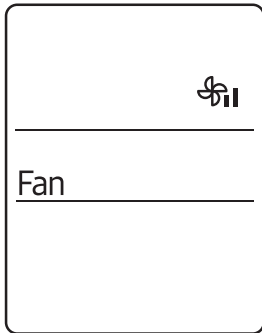

Fan mode

Use the Fan mode to run the air conditioner like a common fan. The air conditioner provides a natural breeze.



NOTE

- If the air conditioner will not be used for an extended period of time, dry the air conditioner by running it in the Fan mode for 3 or 4 hours.

Variety Smart Features

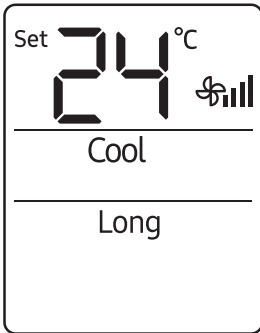
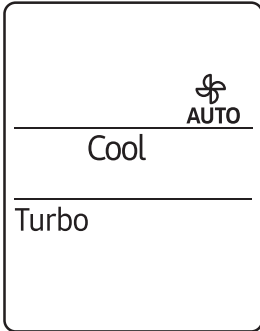

Turbo function

Use the Turbo function to quickly cool your room. This function provides the most powerful cooling air.



NOTE

- To turn off the Turbo function, press **Turbo** (Turbo) button again.
- This function is only available in the Auto and Cool modes.
- When this function is run for 30 minutes, the air conditioner automatically returns to the previous mode.
- You cannot use this function and the Long reach function at the same time.
- You can change the air flow direction.
- You cannot change the set temperature and the fan speed.

Long reach function

Use the Long reach function to extend the area cooled by the air conditioner.



NOTE

- To turn off the Long reach function, press the **Options** (Options) button and directional button to select Long, and then press the **SET** (SET) button.
- You cannot use this function and the Turbo function at the same time.
- You can change the horizontal air flow direction.
- You cannot change the fan speed.
- You cannot use this function in the Dry and Fan modes.

Variety Smart Features

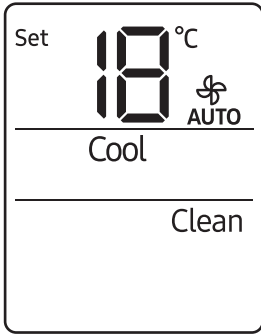



Clean function

Use the Clean function to remove moisture from the inside of the air conditioner for preventing propagation of fungi, bacteria, etc.



- When the Clean function is set, the  (Clean) indicator appears on the indoor unit display. When the air conditioner is ended, the Clean function starts for 10 minutes and then the air conditioner turns off.
- When the Clean runs with the air conditioner off, cleaning runs for 10 minutes and then the air conditioner turns off.
- Once the Clean function is started, it automatically continues to operate until it is cancelled.

NOTE

- When you reactivate the Clean function while Clean function is running, the cleaning stops immediately.
- The Clean function operates only in Auto, Cool and Dry modes.
- Although the **Clean** appears on the remote control in Auto (Heat), Fan and Heat modes, the Clean function does not operate.
- Clean function runs only when the air conditioner operates for over 20 seconds in Auto, Cool and Dry modes.
- Although the **Clean** appears on the remote control with the Timed off active, the cleaning does not operate.
- The  (Clean) indicator does not disappear on the indoor unit display when you turn off the air conditioner with the Clean function active. This is a normal operation.
- While in Clean function, the other indicators other than  (Clean) disappear on the indoor unit display. This is a normal operation.
- When the Clean function runs, it starts with a low fan speed and after a certain period of time, the fan speed becomes strong.

Energy-Saving Operation

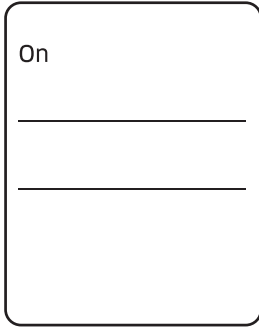

(When the air conditioner is off)

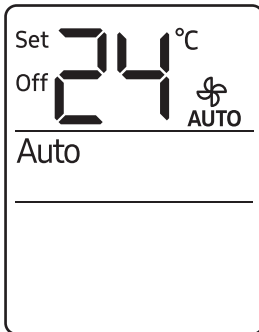

(When the air conditioner is on)

Timed on/Timed off function

Use the Timed on/off function to turn the air conditioner on or off after the time that you set.

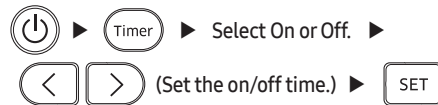

NOTE

- You can set a time between 0.5 and 24 hours.
- To cancel the Timed on/off function, set the time interval to 0.0 on the remote control, or press the (Power) button on the control panel.
- After starting the Timed on function, you cannot change the fan speed.
- Once you start the Timed on/off function, the (Timer) indicator is displayed on the indoor unit display.
- After starting the Timed on function, you can change the mode and the set temperature. You cannot change the set temperature while the Fan mode is running.
- You cannot set the same time for both of the Timed on and Timed off functions.

Combining Timed on and Timed off	
When the air conditioner is off	Example) Timed on: 3 hours, Timed off: 5 hours The air conditioner turns on after 3 hours from the moment you start Timed on/off, remains on for 2 hours, then turns off automatically.
When the air conditioner is on	Example) Timed on: 3 hours, Timed off: 1 hour The air conditioner turns off after 1 hour from the moment you start Timed on/off, then turns on after 2 hours from the moment it is turned off.

Cleaning at a Glance

Cleaning the indoor unit exterior and outdoor unit heat exchanger

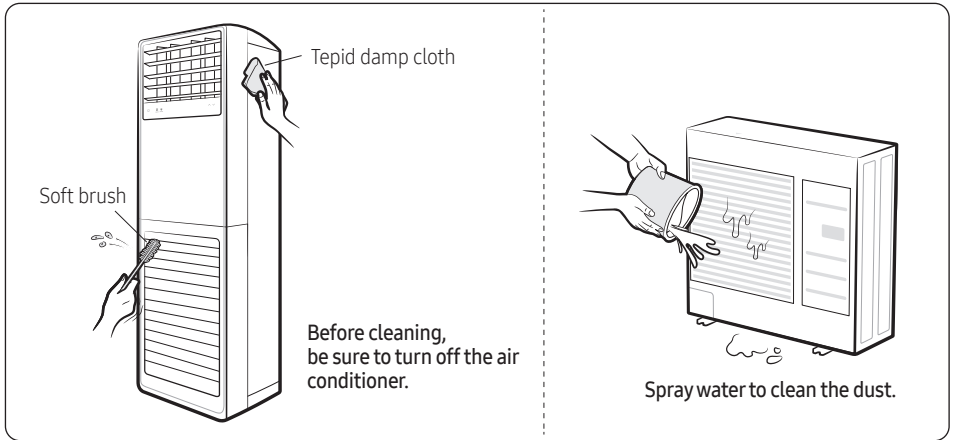

CAUTION

- Do not open the panel when the air conditioner is operating. This action may cause a malfunction or an electrical hazard.
- Do not clean the display by using alkaline detergent.
- Do not use sulphuric acid, hydrochloric acid, or organic solvents (such as thinner, kerosene, and acetone) to clean the surfaces. Do not put any stickers on it as this can damage the surface of the air conditioner.
- When you clean and inspect the heat exchanger on the indoor and outdoor units, contact the local service centre for help.
- Be sure to prevent any injury from sharp edges of the surface when handling the heat exchanger.
- If the air conditioner is running in specific environment such as a restaurant or a hair salon, it may generate unpleasant odours. To prevent odours, ventilate the room properly, clean the air filter, or operate the air conditioner in the Fan mode. If the problem still exists, contact a service centre.

Cleaning the filter

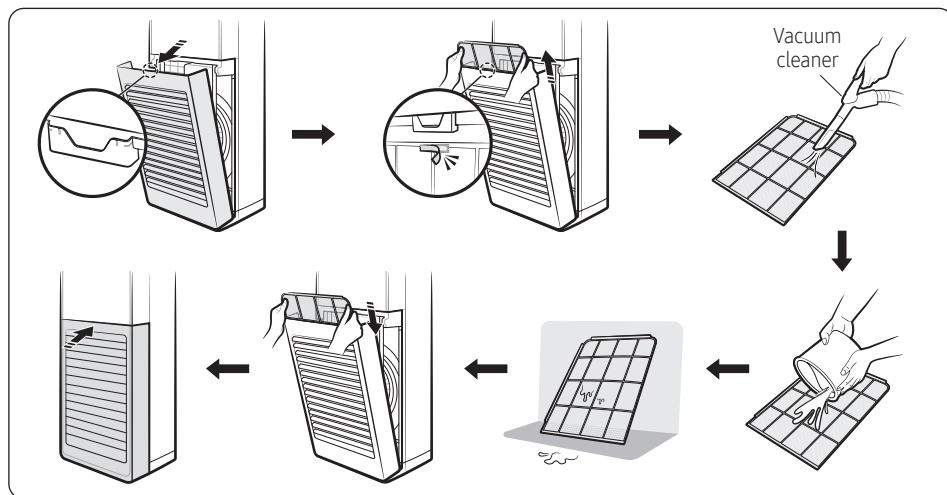

CAUTION

- Do not scrub the air filter with a brush or other cleaning utensil. This may damage the filter.
- Do not expose the air filter to direct sunlight when drying it.

NOTE

- Clean the air filter every 2 weeks. Cleaning term may vary depending on the usage and environmental conditions.
- If the air filter dries in a humid area, it may produce offensive odours. Clean it again and dry it in a well-ventilated area.

Cleaning at a Glance

Periodical maintenance





Unit	Maintenance item	Interval	Requires qualified technicians
Indoor unit	Clean the air filter.	Once every 2 weeks	
	Clean the condensate drain pan.	Once a year	Required
	Clean up the heat exchange.	Once a year	Required
	Clean the condensate drain pipe.	Once every 4 months	Required
	Replace the remote control Batteries.	Once a year	
Outdoor unit	Clean the heat exchanger on the outside of the unit.	Once every 4 months	Required
	Clean the heat exchanger on the inside of the unit.	Once a year	Required
	Clean the electric components with jets of air.	Once a year	Required
	Verify that all the electric components are firmly tightened.	Once a year	Required
	Clean the fan.	Once a year	Required
	Verify that the fan assemblies are firmly tightened.	Once a year	Required
	Clean the condensate drain pan.	Once a year	Required

CAUTION

- Be sure to perform the maintenance check periodically. This work improves the air conditioner's efficiency.
- The frequency of maintenance work may vary depending on the geographical area, amount of dust, and other environmental elements. If the air conditioner is installed in a very dusty place, perform the maintenance work more frequently.
- Make sure that the maintenance work must be done by qualified technicians. For more detailed information, refer to the Installation manual.

Troubleshooting

Refer to the following chart if the air conditioner operates abnormally. This may save time and unnecessary expense.

Problem	Solution
The air conditioner does not operate at all.	<ul style="list-style-type: none"> Check whether the power is turned on, and then operate the air conditioner again. Check whether the auxiliary power switch (ELCB, ELB) is turned on. If the auxiliary power switch (ELCB, ELB) is turned off, the air conditioner does not work although you press the  (Power) button. When you clean the air conditioner or do not use it for an extended period of time, turn off the auxiliary power switch (ELCB, ELB). <p> NOTE</p> <ul style="list-style-type: none"> The auxiliary power switch (ELCB, ELB) is sold separately. Make sure that auxiliary power switch (ELCB, ELB) is installed in the distribution box inside the building. If the air conditioner is turned off by the Timed off function, turn on the air conditioner again by pressing the  (Power) button.
The temperature does not change.	<ul style="list-style-type: none"> Check whether the Auto or Fan mode, or the Turbo function is running. In these modes and function, the air conditioner controls the set temperature automatically, and you cannot change the set temperature.
The fan speed does not change.	<ul style="list-style-type: none"> Check whether the Auto or Dry mode, or the Turbo or Long reach function is running. In these modes and functions, the air conditioner controls its fan speed automatically, and you cannot change the fan speed.
The air flow direction does not change.	<ul style="list-style-type: none"> Check whether the Long reach function is running. In the Long reach function, only horizontal air flow direction can be changed.
The wireless remote control does not operate.	<ul style="list-style-type: none"> Check whether the batteries are discharged. Replace the batteries with new ones. Make sure that nothing is blocking the remote control sensor. Check whether any strong lighting sources are near the air conditioner. Strong light which comes from fluorescent bulbs or neon signs may interfere with the remote control.
The Timed on/off function does not operate.	<ul style="list-style-type: none"> Check whether you pressed the  (SET) button on the remote control after setting the on/off time. Set the on/off time.
The indoor unit display blinks continuously.	<ul style="list-style-type: none"> Check whether E2-01, E2-02 is displayed on the indoor unit display. Make sure that the power and communication cables are connected correctly between the indoor and outdoor units, and then restart the air conditioner. If the error is still displayed, contact a service centre. Check whether the following errors are displayed on the indoor unit display: E2-03, E2-21, E2-31, E2-51, E3-20, E4-03, E4-04, E4-16, E4-40, E4-41, E4-58, E4-75, E4-61, E4-62, E4-63, E4-64, E4-65, E4-66, E4-67, E4-68, E4-71, E4-74, E4-84, E5-00, E5-54, E5-56, E5-57, E5-08, E4-70, E4-22, E5-90, E1-98

Troubleshooting

Problem	Solution
<p>Air does not come out of the air conditioner.</p>	<ul style="list-style-type: none"> • In the Cool mode, air does not come out if the set temperature is higher than the current temperature. • Cooling does not operate in the Fan mode. Select the Cool, Auto, or Dry mode. • Check whether the air filter is blocked with dirt. A dusty filter may decrease the cooling efficiencies. Clean the air filter frequently. • If a cover is on the outdoor unit or any obstacle is present near the outdoor unit, remove them. • Install the outdoor unit in a well-ventilated place. Avoid places exposed to direct sunlight or close to a heating appliance. • Place a sunscreen over the outdoor unit to protect it from direct sunlight. • If the indoor unit is installed in a place exposed to direct sunlight, pull the curtains on the windows. • Close the windows and doors to maximize the cooling efficiencies. • If the Cool mode is stopped and then started immediately, cool air comes out after about 3 minutes to protect the compressor of the outdoor unit. • If the refrigerant pipe is too long, the cooling efficiencies may be decreased. Avoid exceeding the maximum pipe length.
<p>The air conditioner makes strange noises.</p>	<ul style="list-style-type: none"> • In certain conditions (especially, when the outdoor temperature is lower than 20°C), a hissing, rumbling, or splashing sound may be heard while the refrigerant is circulating through the air conditioner. This is a normal operation.
<p>Unpleasant odours permeate the room.</p>	<ul style="list-style-type: none"> • If the air conditioner is running in a smoky area or if there is a smell entering from outside, ventilate the room properly. • If the air conditioner has not been operated for an extended period of time, clean the indoor unit and operate the air conditioner in Fan mode for 3 to 4 hours to dry the inside of the indoor unit for removal of unpleasant odours. • If the air filter blocked with dirt, clean the air filter.
<p>Water drops from the piping connections of the outdoor unit.</p>	<ul style="list-style-type: none"> • Condensation may develop due to the difference in temperature. This is a normal condition.

Safety Information (Installing the Air Conditioner)

Carefully follow the precautions listed as below because they are essential to guarantee the safety of SAMSUNG product.



WARNING

- Always disconnect the air conditioner from the power supply before servicing it or accessing its internal components.
- Verify that installation and testing operations are performed by qualified personnel.
- Verify that the air conditioner is not installed in an easily accessible area.

General information

- Carefully read the content of this manual before installing the air conditioner and store the manual in a safe place in order to be able to use it as reference after installation.
- For maximum safety, installers should always carefully read the following warnings.
- Store the manual in a safe location and remember to hand it over to the new owner if the air conditioner is sold or transferred.
- This manual explains how to install an indoor unit with a split system with two SAMSUNG units. The use of other types of units with different control systems may damage the units and invalidate the warranty. The manufacturer shall not be responsible for damages arising from the use of non compliant units.
- The manufacturer shall not be responsible for damage originating from unauthorized changes or the improper connection of electric and hydraulic lines. Failure to comply with these instructions or to comply with the requirements set forth in the "Operating limits" table, included in the manual, shall immediately invalidate the warranty.
- The air conditioner should be used only for the applications for which it has been designed: the indoor unit is not suitable to be installed in areas used for laundry.
- Do not use the units if damaged. If problems occur, switch the unit off and disconnect it from the power supply.
- In order to prevent electric shocks, fires or injuries, always stop the unit, disable the protection switch and contact SAMSUNG's technical support if the unit produces smoke, if the power cable is hot or damaged or if the unit is very noisy.
- Always remember to inspect the unit, electric connections, refrigerant tubes and protections regularly. These operations should be performed by qualified personnel only.
- The unit contains moving parts, which should always be kept out of the reach of children.
- Do not attempt to repair, move, alter or reinstall the unit. If performed by unauthorized personnel, these operations may cause electric shocks or fires.
- Do not place containers with liquids or other objects on the unit.
- All the materials used for the manufacture and packaging of the air conditioner are recyclable.
- The packing material and exhaust batteries of the remote control (optional) must be disposed of in accordance with current laws.
- The air conditioner contains a refrigerant that has to be disposed of as special waste. At the end of its life cycle, the air conditioner must be disposed of in authorized centers or returned to the retailer so that it can be disposed of correctly and safely.
- Wear protective equipment (such as safety gloves, goggles, and headgear) during installation and maintenance works. Installation/repair technicians may be injured if protective equipment is not properly equipped.
- This appliance is not intended for use by persons (including children) with reduced physical, sensory or mental capabilities, or lack of experience and knowledge, without supervision or instruction concerning use of the appliance by a person responsible for their safety. Children should be supervised to ensure that they do not play with the appliance.

Safety Information (Installing the Air Conditioner)

Installing the unit

IMPORTANT: When installing the unit, always remember to connect first the refrigerant tubes, then the electrical lines. Always disassemble the electric lines before the refrigerant tubes.

- Upon receipt, inspect the product to verify that it has not been damaged during transport. If the product appears damaged, DO NOT INSTALL it and immediately report the damage to the carrier or retailer (if the installer or the authorized technician has collected the material from the retailer).
- After completing the installation, always carry out a functional test and provide the instructions on how to operate the air conditioner to the user.
- Do not use the air conditioner in environments with hazardous substances or close to equipment that release free flames to avoid the occurrence of fires, explosions or injuries.
- Our units must be installed in compliance with the spaces indicated in the manual to ensure either accessibility from both sides or ability to perform routine maintenance and repairs. The units' components must be accessible and that can be disassembled in conditions of complete safety either for people or things. For this reason, where it is not observed as indicated into the manual, the cost necessary to reach and repair the unit (in safety, as required by current regulations in force) with slings, trucks, scaffolding or any other means of elevation won't be considered in-warranty and charged to end user.

Power supply line, fuse or circuit breaker

- For this reason, when provisions of the installation manual are not complied with, the cost required to access and repair the units (in SAFETY CONDITIONS, as set out in prevailing regulations) with harnesses, ladders, scaffolding or any other elevation system will NOT be considered part of the warranty and will be charged to the end customer.
- Always make sure that the power supply is compliant with current safety standards. Always install the air conditioner in compliance with current local safety standards.
- Always verify that a suitable grounding connection is available.
- Verify that the voltage and frequency of the power supply comply with the specifications and that the installed power is sufficient to ensure the operation of any other domestic appliance connected to the same electric lines.
- Always verify that the cut-off and protection switches are suitably dimensioned.
- Verify that the air conditioner is connected to the power supply in accordance with the instructions provided in the wiring diagram included in the manual.
- Always verify that electric connections (cable entry, section of leads, protections...) are compliant with the electric specifications and with the instructions provided in the wiring scheme. Always verify that all connections comply with the standards applicable to the installation of air conditioners.
- Be sure not to perform power cable modification, midway wiring, and multiple wire connection.
 - It may cause electric shock or fire due to poor connection or insulation and current limit override.
 - When midway wiring is required due to power line damage, refer to "Step 2.4 Optional: Extending the power cable" in the installation manual.

CAUTION

- Make sure that you earth the cables.
 - Do not connect the earth wire to the gas pipe, water pipe, lighting rod or telephone wire. If earthing is not complete, electric shock or fire may occur.
- Install the circuit breaker.
 - If the circuit breaker is not installed, electric shock or fire may occur.
- Make sure that the condensed water dripping from the drain hose runs out properly and safely.
- Install the power cable and communication cable of the indoor and outdoor unit at least 1m away from the electric appliance.
- Install the indoor unit away from lighting apparatus using the ballast.
 - If you use the wireless remote control, reception error may occur due to the ballast of the lighting apparatus.
- Do not install the air conditioner in following places.
 - Place where there is mineral oil or arsenic acid. Resin parts flame and the accessories may drop or water may leak. The capacity of the heat exchanger may reduce or the air conditioner may be out of order.
 - The place where corrosive gas such as sulfurous acid gas generates from the vent pipe or air outlet. The copper pipe or connection pipe may corrode and refrigerant may leak.
 - The place where there is a machine that generates electromagnetic waves. The air conditioner may not operate normally due to control system.
 - The place where there is a danger of existing combustible gas, carbon fiber or flammable dust. The place where thinner or gasoline is handled. Gas may leak and it may cause fire.

Installation Procedure

Step1 Choosing the installation location

Determine the installation location considering the following conditions and obtain the user approval.

Indoor unit

- Install the unit where the pipes and cables can be easily connected to the outdoor unit.
- Install the unit where there are no obstacles against the wind around the air intake and air outlet.
- Install the unit on a flat and stable surface that can hold the unit's weight. Otherwise, the unit may generate noise and vibrations.
- Do not install the unit near highly frequented doors and passages.
- Do not install the unit in a location exposed to direct sunlight.

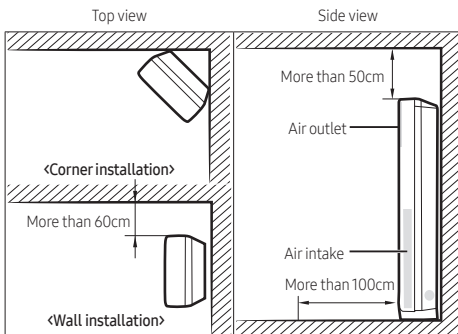

- If there is any unavoidable reason to install the unit at such a place, take the following measures:
 - When installing the unit at a roadside concentrated with buildings, install it parallel to the road.
 - Install the unit so that the air outlet faces the wall such as rooftop that may be subjected to strong wind.

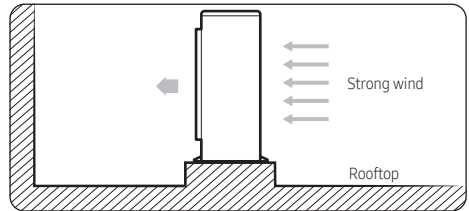

- When installing the outdoor unit near the seashore, make sure that it is not directly exposed to sea breeze. If you cannot find an adequate place, a protection wall should be constructed.
 - Install the outdoor unit at a place (such as near a building) where it can be protected from sea breeze. Failure to do so may cause damage to the outdoor unit.

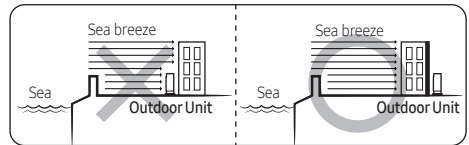

- If you cannot avoid a place near the seashore, construct a protection wall around the outdoor unit.

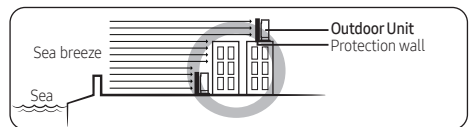

Outdoor unit

- Install the unit where it will not experience oil leakages, salt collection, gas exposure, or sulfide gas risk, and keep it safe from other dangers.
- Install the unit where does not disturb your neighbors as they may be affected by the noise or airflow coming from the unit.
- Install the unit where no rainwater can collect on or near it.
- Install the unit in a well-ventilated location away from direct sunlight or strong winds.
- Install the unit where the pipes and cables can be easily connected to the indoor unit.
- Maintain sufficient space for repairs and service.
- Make sure that condensed water dripping from the drain hose is directed away safely.

- Construct a protection wall made of solid material such as concrete to block sea breeze. Make sure that its height and width are 1.5 times greater than the size of the outdoor unit. In addition, secure a space larger than 600 mm between the protection wall and the outdoor unit for exhausted air to ventilate.
- Install the unit at a place where water can drain smoothly.
- If you have any difficulty in finding an installation location, contact your manufacturer.
- Be sure to clean sea water and dust on the heat exchanger of the outdoor unit and apply a corrosion inhibitor on it (at least once in a year).

- Check the condition of the product periodically.
 - Check the installation site every 3 months and perform anti-corrosion treatment such as R-Pro supplied by SAMSUNG (Code: MOK-220SA) or commercial water repellent grease and wax, etc., based on the product condition.
 - When the product is to be shut down for a long period of time, such as off-peak hours, take appropriate measures like covering the product.
- If the product installed within 500m of seashore, special anti-corrosion treatment is required.
 - ※ Please contact your local SAMSUNG representative for further details.

Outdoor unit installation request

- The suggested space is based on the outdoor temperature of 35°C while in operation. If the outdoor temperature is higher than 35°C, secure more space.
- Be sure to secure sufficient clearance for a person and air flow passage.
- See the clearances and dimensions in Minimum clearances for the outdoor unit (page 33) when installing the outdoor unit.
- If you install multiple outdoor units in the same place, be sure to secure enough space for ventilation and free airflow.
- If the space for ventilation is insufficient, the air conditioner may not perform well as designed.

Minimum clearances for the outdoor unit

When installing 1 outdoor unit

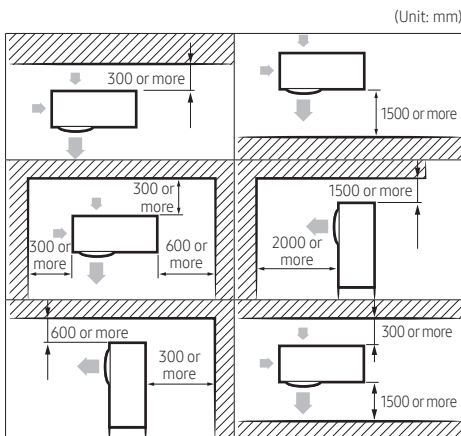

When installing more than 1 outdoor unit

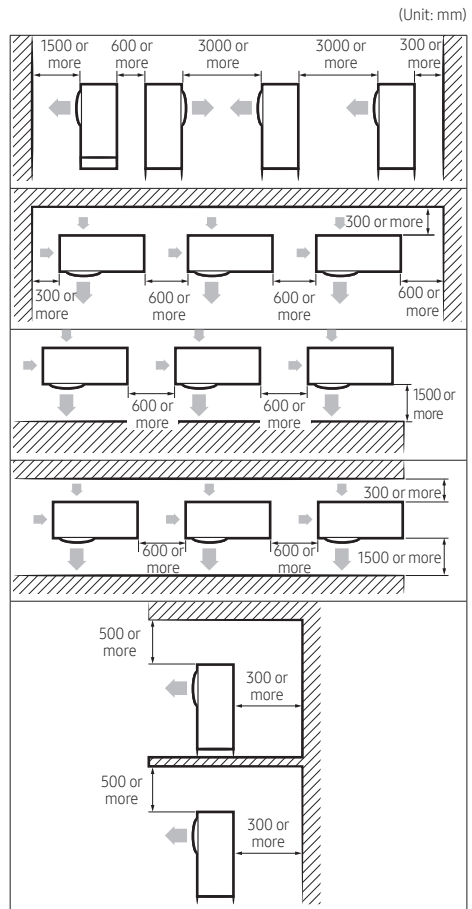

⚠ CAUTION

- The outdoor unit must be installed according to the specified distance in order to permit accessibility from each side, to guarantee correct operation, maintenance, and repair of the unit. The components of the outdoor unit must be reachable and removable under safe conditions for people and the unit.

Installation Procedure

WARNING

- Should adopt bar type louver. Don't use a type of rain resistance louver.

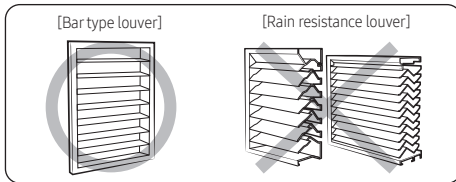

- Louver specifications.
 - Angle criteria : less than 20°
 - Opening ratio criteria : greater than 80%

WARNING

- After installing the outdoor unit, apply rust inhibitor on the internal pipes and heat exchanger.
 - Airborne corrosive gas such as sulfur compounds, hydrogen sulfide, and ammonia, or salty dust may cause pipe corrosion. This corrosion may result in refrigerant leakage.
 - Inspect the outdoor unit at least once a year and re-apply the rust inhibitor where it is damaged or worn out.
- When applying rust inhibitor, be sure to follow the instructions below:
 - Turn off the power before spraying the rust inhibitor.
 - Wear protective goggles and a mask in advance.
 - Clean the dusty surface with clean fabric or paper before spraying the inhibitor.
 - Make sure that wind is blowing from behind the worker.
 - Do not spray on the PCB panel and electric parts.

CAUTION

- Install the indoor unit away from any interference, such as radios, computers, and stereo devices, and also select the place where the electrical wiring work is possible.
 - Keep the unit at least 3 m away from electronic devices that generate electromagnetic waves, and install a protection tube for the main power cable and communication cable.
 - Make sure that there is no device that can generate electromagnetic waves. Otherwise, a malfunction of the control system may occur. For example, the indoor unit remote control sensor may not properly receive signals near fluorescent lamps because of interference.
- Be sure to install the outdoor unit in a safe place where it is not affected by snowfall. The frame should be installed in a place where the air inlet and heat exchanger of the unit are not buried under snow.
- A ventilation system is required when the outdoor unit is installed in a closed space or room, even though R-410A is not poisonous or flammable.
- Install the railing around the outdoor unit to prevent falling when installed at a high place.
- Avoid installation near exhaust pipes and ventilating openings exposed to corrosive gas, sulfur oxide, ammonia, or sulfur gas herbicide. Installations near these places require anticorrosive treatments. Contact the manufacturer to avoid corrosion of copper pipes or soldered parts.
- Depending on the power supply, electric noise or unstable voltage may happen after malfunctions of the electrical parts or the control system particularly on ships or other places using generators.

Moving the outdoor unit with wire rope

- 1 Before carrying the outdoor unit, fasten two wire ropes of 8 m or longer, as shown in the figure.
- 2 To prevent damages or scratches effectively, insert a piece of cloth between the outdoor unit and the ropes.
- 3 Move the outdoor unit.

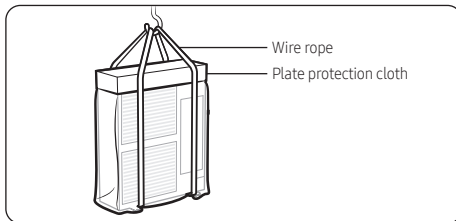
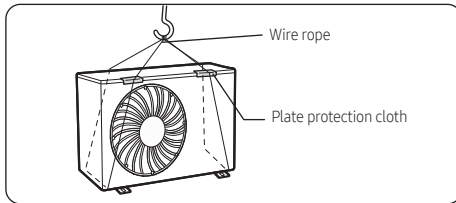

- The appearance of the unit may be different from the picture depending on the model.

Fixing the outdoor unit in place

Fix the outdoor unit with anchor bolts. Make sure that the anchor bolts are 20 mm or higher from the base surface.

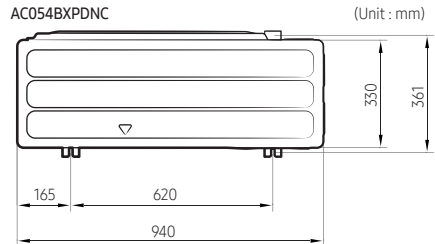
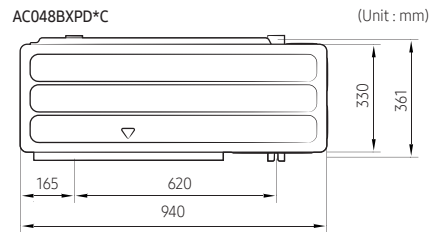
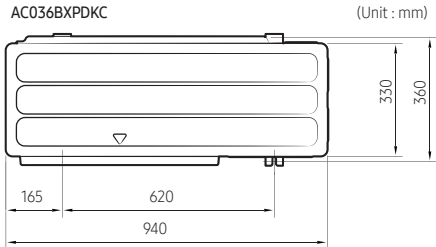
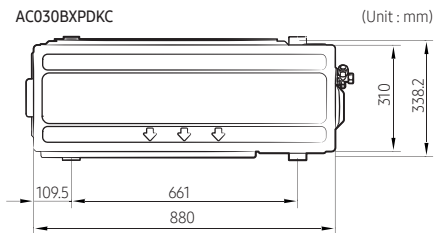

⚠ CAUTION

- Install a drain outlet at the lowest end around the base for the outdoor unit drainage.
- When installing the outdoor unit on the roof, waterproof the unit and check ceiling strength.

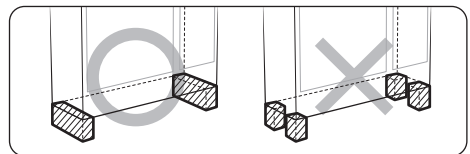

- Make sure that the wall can support the weights of the rack and the outdoor unit.
- Install the rack close to the column as much as possible.

Installation Procedure

Optional: Fixing the outdoor unit to a wall with a rack

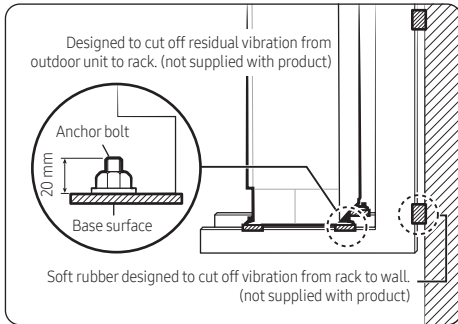

- Install a proper grommet in order to reduce noise and residual vibration transferred by the outdoor unit towards the wall.

CAUTION

- When installing an air guide duct, be sure to check the following:
 - The screws do not damage the copper pipe.
 - The air guide duct is fixed firmly on the guard fan.

Step 2 Unpacking

Unpacking the indoor unit

- 1 Open the indoor unit package.
- 2 Remove the top and middle cushions.
- 3 Remove the bottom cushion.







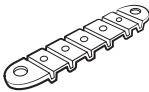

Unpacking the outdoor unit

- 1 Pull out the outdoor unit from the package.
- 2 Remove the top cushion.
- 3 Remove the 4 screws from the wooden pallet.
- 4 Remove the wooden pallet.

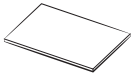

Step 3 Checking and preparing accessories

The following accessories are supplied with the air conditioner. Their type and quantity may differ depending on the specifications.

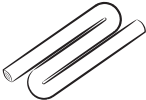
Accessories in the indoor unit package

Fixing bracket for indoor unit (1)	Remote control (1)
	
Installation manual (1)	Remote control holder (1)
	
Batteries for remote control (2)	Insulation for piping(1)
	
M4 X L12 screws (4)	M4 X L14 screws (4)
	
Pipe outlet protection rubber (1)	Insulation for drain hose (1)
	

Accessories in the outdoor unit package

Drain cap (3)	Drain plug out (1)
	
Rubber leg (4)	
	

Step 4 Drilling a hole through a wall

- 1 Determine the position of a 60 to 65 mm hole considering possible directions of the pipe bundle and minimum distances between the hole and installation plate.
- 2 Drill the hole that slopes slightly downward (15°).

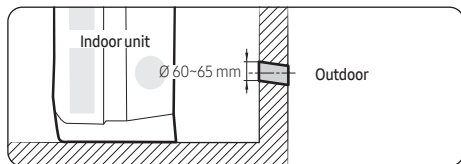

Step 5 Taping the pipes, cables, and drain hose

- 1 Wrap the refrigerant pipes with the provided insulation. This wrapping minimises condensation.

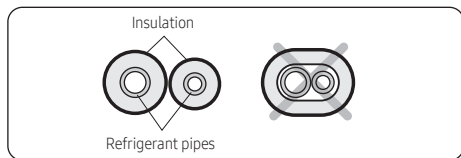

NOTE

Select the insulation of the refrigerant pipe.

- When the accessory parts box (FPC*****) is used, be sure to use the insulator in the accessory parts box. However if installing in a high humidity condition, use thicker insulator by referring to the table below. If installing in an unfavourable conditions, use thicker one.
- Insulate the gas side and liquid side pipe, noting the insulation thickness that must differ according to the pipe size.
- Standard: Less than an indoor temperature of 30°C, with humidity at 85%. If installing in a high humidity environment, use one grade thicker insulator by referring to the table below. If installing in an unfavourable environment, use thicker one.
- The heat-resistance temperature of the insulator must be more than 120°C.

Pipe	Pipe size (mm)	Insulation type (heating/cooling)		Remarks
		Standard (Less than 30°C, 85%)	High humidity (Over 30°C, 85%)	
		EPDM, NBR		
Liquid pipe	Ø6.35 to Ø9.52	9t	9t	The internal temperature is higher than 120°C.
	Ø12.7 to Ø19.05	13t	13t	
Gas pipe	Ø6.35	13t	19t	
	Ø9.52	19t	25t	
	Ø12.70			
	Ø15.88			
Ø19.05				

- When installing insulation in the places and conditions below, use the same insulation that is used for high humidity conditions.

<Geological condition>
High humidity locations such as shorelines, hot springs, lake or riversides, and ridges (when part of the building is covered by earth and sand)
<Operation purpose condition>
Restaurant ceiling, sauna, swimming pool etc.
<Building construction condition>
Ceilings frequently exposed to moisture and cooling are not covered. For example, pipes installed at a corridor of a dormitory and studio or near an exit that opens and closes frequently. Places (where the pipes are installed) that are highly humid due to a lack of ventilation.

- 2 Wind the refrigerant pipes, power cable, communication cable, and drain hose with vinyl tape to make a pipe bundle.

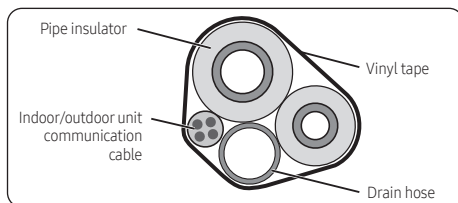

Installation Procedure

NOTE

- Be sure to insulate the pipes without gaps or cracks, and use adhesive between the connecting parts of the insulation to prevent moisture from entering.
- When bending the pipe, try to secure a large bending radius (over 100 mm) to prevent the copper pipe from distorting.
- Make sure that the thickness of the insulation does not get thinner on the pipe's bending area.
- When the insulation thickness becomes thinner, use extra insulation to maintain thickness.
- When installing the pipe hanger, use extra PE-foam insulation (over 5 mm) to make the width of the insulation 3 times wider than the hanger. Do not use cable ties as a pipe hanger.

Step 6 Purging inert gas from the indoor unit

The indoor unit comes with nitrogen gas (inert gas) charged at the factory. Therefore, all inert gas must be purged before connecting the assembly piping.

Unscrew the pinch pipe at the end of each refrigerant pipe.

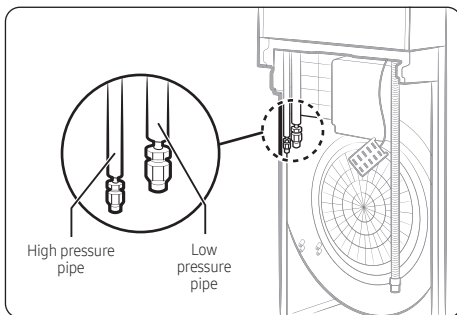

NOTE

- To prevent dirt or foreign objects from getting into the pipes during installation, do not remove the pinch pipe completely until you are ready to connect the piping.

Step 7 Optional: Cutting and flaring the pipes

- 1 Make sure that you have the required tools available: pipe cutter, reamer, flaring tool, and pipe holder.
- 2 If you wish to shorten the pipes, cut them with a pipe cutter, ensuring that the cut edge remains at a 90° angle to the side of the pipe. Refer to the illustrations below for examples of edges cut correctly and incorrectly.

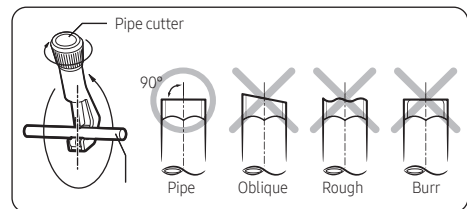

- 3 To prevent any gas from leaking out, remove all burrs at the cut edge of the pipe, using a reamer.
- 4 Slide a flare nut on to the pipe and modify the flare.

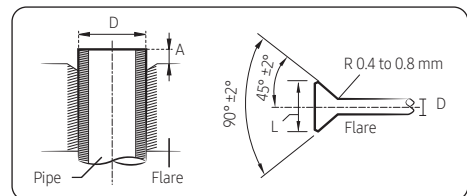

Outer Diameter (D)	Depth (A)	Flare dimension (L)
Ø 6.35 mm	1.3 mm	8.7 to 9.1 mm
Ø 9.52 mm	1.8 mm	12.8 to 13.2 mm
Ø 12.70 mm	2.0 mm	16.2 to 16.6 mm
Ø 15.88 mm	2.2 mm	19.3 to 19.7 mm
Ø 19.05 mm	2.2 mm	23.6 to 24.0 mm

- 5 Check that the flaring is correct, referring to the illustrations below for examples of incorrect flaring.

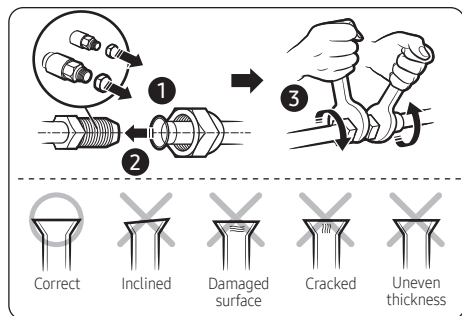

CAUTION

- If the pipes require brazing ensure that OFN (Oxygen Free Nitrogen) is flowing through the system.
- Nitrogen blowing pressure range is 0.02 to 0.05 MPa.

Step 8 Connecting the refrigerant pipes

Items	Maximum allowable length [m]	
Outdoor unit models	AC030BXPDKC AC036BXPDKC	AC048BXPDKC AC054BXPDKC
Main pipe (L1)	50	75
Max. height difference between outdoor and indoor unit (h1)	30	50

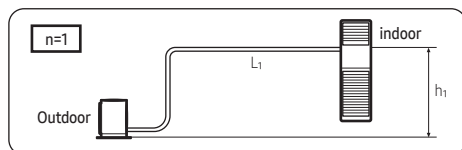

- Temper grade and minimum thickness of the refrigerant pipe

Outer diameter [mm]	Minimum thickness [mm]	Temper grade
ø6.35	0.7	C1220T-O
ø9.52	0.7	
ø12.70	0.8	
ø15.88	1.0	
ø15.88	0.8	C1220T-1/2H OR C1220T-H
ø19.05	0.9	
ø22.23	0.9	

- 1 Connect each assembly pipe to the appropriate valves on the indoor and outdoor units and fasten the flare nuts.
- 2 As depicted in the illustration below, tighten the flare nut manually, and then apply the following torque with a torque wrench.

Indoor unit

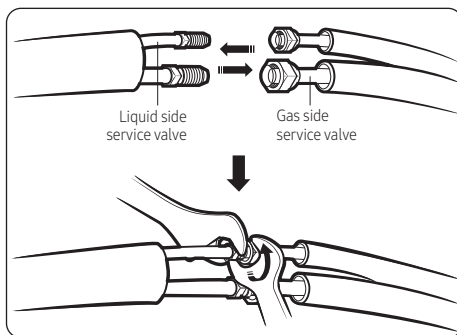

Installation Procedure

Outdoor unit

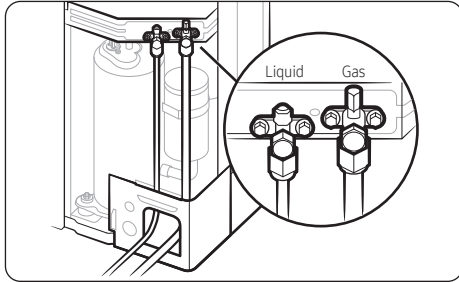

Outer Diameter (D, mm)	Fastening torque (N·m)
6.35	14 to 18
9.52	34 to 42
12.7	49 to 61
15.88	68 to 82
19.05	100 to 120

⚠ WARNING

- During installation, make sure that there is no gas leakage. When collecting refrigerant, first stop the compressor. If the refrigerant pipe is not properly connected and compressor runs with the service valve open, the pipe takes in air and the pressure rises, which may cause explosion or injury.

⚠ CAUTION

- Be sure to use C1220T-1/2H(Semi-hard) pipe for bigger than Ø19.05 mm. If you use C1220T-0(Soft) for bigger than Ø19.05 mm, the pipe may be broken, which can result in an injury.

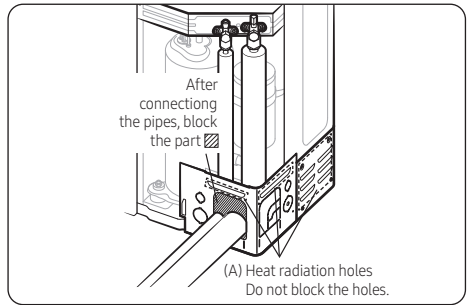
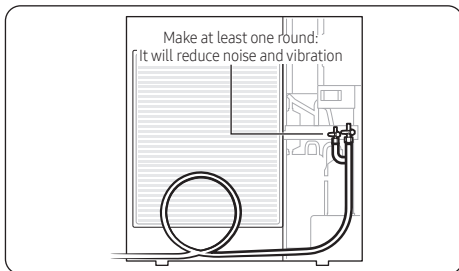

- The appearance of the unit may be different from the diagram depending on the model.

⚠ CAUTION

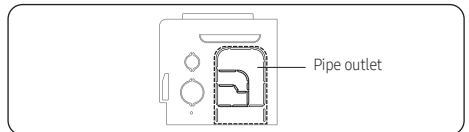

- Cut the pipe outlet to the exact pipe size. In addition, remove foreign substances and burrs around the outlet.
- Perform cutting with only a cutter (ex. nipper) and never tap with a hammer near the pipe outlet. Otherwise, it may cause product damage such as warping of the cabinet.
- After connecting the pipes with Pipe outlet, plug the space around the pipes.
- After connecting the pipes, proceed exactly as directed in the guide to prevent interference with the internal parts.
- Tighten the nuts to the specified torques. If overtightened, the nuts could be broken so refrigerant may leak.
- Protect or enclose refrigerant tubing to avoid mechanical damage.
- After installing pipes, block the unused knock hole to prevent small animal from entering. However, the radiant heat hole(A) should be able to intake air.

Step 9 Connecting the power and communication cables

CAUTION

- Always remember to connect the refrigerant pipes before performing the electric connections. When disconnecting the system, always disconnect the electric cables before disconnecting the refrigerant pipes.
- Always remember to connect the air conditioner to the grounding system before performing the electric connections. Use a crimp ring terminal at the end of each wire.

Electrical work must be done by the certified personnel.

- Wiring work should be performed in compliance with related regulations following technical specifications and installation guide.
- Be sure to install an exclusive power supply. If you use a power strip for multiple electrical connections, there is a risk of electric shock or fire.
- Be sure to install a circuit breaker with a rated current sensitivity of over 30 mA.
- Fasten the screws on the terminal block to be within the rated range and so that they do not loosen.
- Be sure to connect the ground wire. Install the power wire and make sure it is shorter than 50 m. If the length of the power wire exceeds 50 m, the product may not work properly or the wire may be damaged.

- 1 Remove the screw on the electrical component box and remove the cover plate.
- 2 Route the cables through the sides or back of the indoor unit and then connect them to the terminals noting the figure below.
- 3 Route the other end of the cable to the outdoor unit through the ceiling & the hole on the wall.
- 4 Reassemble the electrical component box cover, carefully tightening the screw.

AC030/036/048BNPDKC (1-pahse)

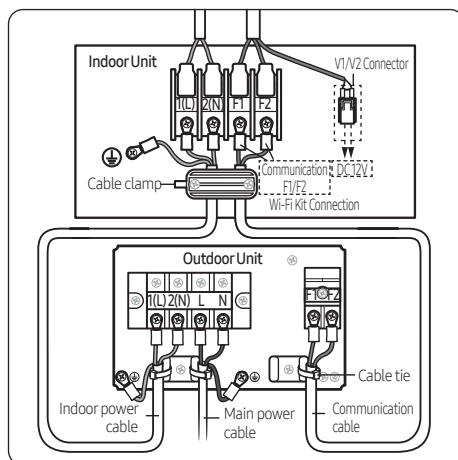

AC048/054BNPDKC (3-pahse)

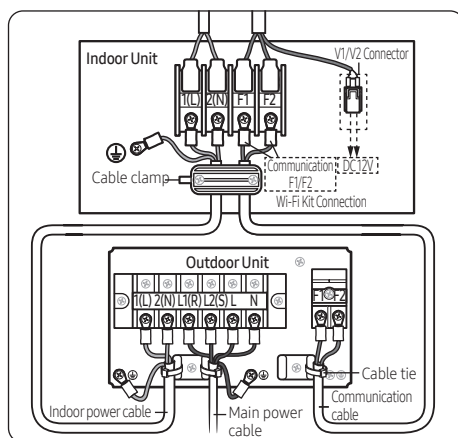

NOTE

- DC12V Connection for Wi-Fi Kit : Cut the wires of the V1/V2 connector and then connect the wires to the Wi-Fi Kit.

Installation Procedure

Outdoor-to-indoor power and communication cables specifications

Indoor power supply		
Power supply	Max/Min (V)	Indoor power cable
1 Φ , 220-240V, 50/60 Hz	$\pm 10\%$	0.75 mm ² \uparrow , 3 wires
Communication cable		
0.75 mm ² , 2 wires		

NOTE

- Power supply cords of parts of appliances for outdoor use shall not be lighter than polychloroprene sheathed flexible cord.
 - Code designation
 - [1-phase] IEC: 60245 IEC 57 / CENELEC: H05RN-F grade or more
 - [3-phase] IEC: 60245 IEC 66 / CENELEC: H07RN-F grade or more
- When installing the indoor unit in a computer room or net work room, use the double shielded (tape aluminium / polyester braid + copper) cable of FROHH2R type.

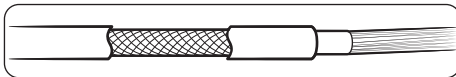

CAUTION

- Use rated cables or products only, with heat resistance over 105°C, as well as properly rated switches or fuses in the cabinet panel.
- Make sure that the cables connected do not produce sparks around the auxiliary power switch or that they are not installed in a place subject to high temperature. High ambient temperature decreases allowable current.
- Install the auxiliary power switch in a dry place, install the panel board or electrical component box, and then install the circuit breaker in the panel board.
- When connecting the main power cable, press the cable to the terminal for a secure connection.
- Select a ring terminal for use.

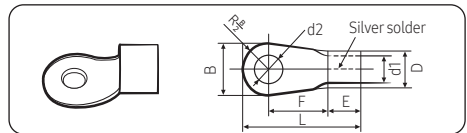

Thickness of the wire (mm ²)	B (mm)	d2 (mm)
2.5	Less than 9.5	More than 4.5
4	Less than 9.5	More than 4.5
6	Less than 9.5	More than 4.5
10	Less than 15	More than 8.4

Connecting the cable to the power terminal

Connect the cables to the terminal board with the ring terminals.

NOTE

- Be sure to use the certified and rated cables and firmly connect them without applying any external force to the ring terminal.
- Connect with a driver and wrench that can apply the rated torque to the screws.
- Connect the terminal screws in compliance with the rated tightening torques.
- If the terminal is loose, a fire may occur, caused by arcing electricity. If the terminal is connected too firmly, the terminal may be damaged.

Screw	Tightening torque for terminal (kgf·cm)
M3	5 to 7.5
M3.5	8 to 12
M4	12 to 18
M5	20 to 30
M6	25 to 37.5

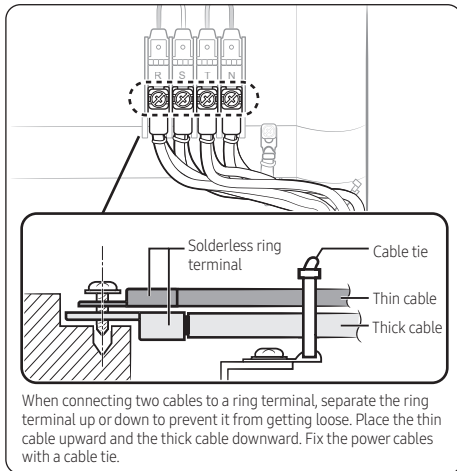

Connecting the cables

- This product uses a single phase power, with 220 to 240V supply.
- When connecting the outdoor-to-indoor power cables, be sure to match the numbers (or letters) between the outdoor and indoor units. Connect the communication cable to the connector included in the electrical component box for each unit. When the outdoor-to-indoor power cables are connected incorrectly, a malfunction of the product may occur.
- When connecting the communication and outdoor-to-indoor power cables, make sure these cables do not touch the service valve on the refrigerant pipe on the gas side or the pipes without proper insulation. Fix the outdoor-to-indoor power cables to the insulated pipes.
- Be sure to comply with the wiring standards, as there may be a risk of fire.
- Make sure to install the circuit breaker firmly inside the electrical component box.

Entire system diagram

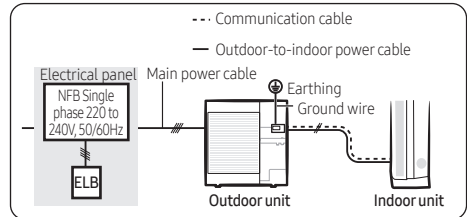

Power wiring diagram

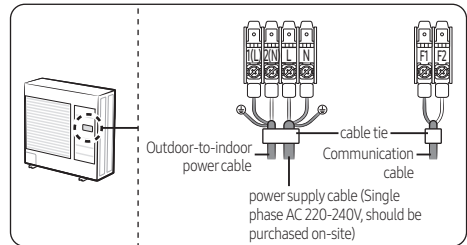

Indoor and outdoor unit connection diagram

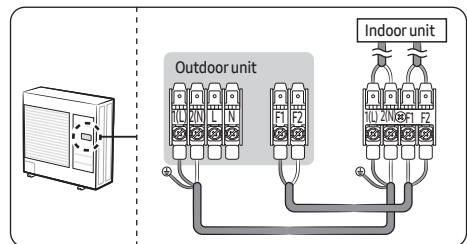

Main power cable specifications

The power cable is not supplied with air conditioner.

- Select the power supply cable in accordance with relevant local and national regulations.
- Wire size must comply with the applicable local and national code.
- Specifications for local wiring power cord and branch wiring are in compliance with local cord.

Installation Procedure





Model		Outdoor unit				Input Current[A]			Power supply	
Outdoor unit	Indoor unit	Rated		Voltage Range		Outdoor (Down_Amp)	Indoor	Total	MCA	MFA
		Hz	Volts	Min.	Max.	Cooling				
AC030BXPDKC	AC030BNPDKC	50/60	220 ~ 240	198	264	20	2.0	22.0	22.0	25.0
AC036BXPDKC	AC036BNPDKC	50/60	220 ~ 240	198	264	24	2.0	26.0	26.0	30.0
AC048BXPDKC	AC048BNPDKC	50/60	220 ~ 240	198	264	32	2.0	34.0	34.0	40.0
AC048BXPDNC	AC048BNPDKC	50/60	380 ~ 415	342	457	12	2.0	14.0	14.0	15.0
AC054BXPDNC	AC054BNPDKC	50/60	380 ~ 415	342	457	12	2.0	14.0	14.0	15.0

NOTE

- Voltage range
 - Units are suitable for use on electrical systems where voltage supplied to unit terminal is not below or above listed range limits
- Maximum allowable voltage variation between phases is 2%.
- Wire size & type must comply with the applicable local and national code.
 - Wire size: Based on the value of MCA.
 - Wire type: 60245 IEC57(IEC) or H05RN-F(CENELEC) grade or more.
- MFA is used to select the circuit breaker and the ground fault circuit interrupter (earth leakage circuit breaker).
- MCA represents maximum input current.
 - MFA represents capacity which may accept MCA
 - Abbreviations
MCA: Min. Circuit Amps. (A)
MFA: Max. Fuse Amps. (A)

Step 10 Optional: Extending the power cable

- Prepare the following tools.

Tools	Spec	Shape
Crimping pliers	MH-14	
Connection sleeve (mm)	20 x Ø6.5 (H x OD)	
Insulation tape	Width 19 mm	
Contraction tube (mm)	70 x Ø8.0 (L x OD)	

- As shown in the figure, peel off the shields from the rubber and wire of the power cable.
 - Peel off 20 mm of cable shields from the pre-installed tube.

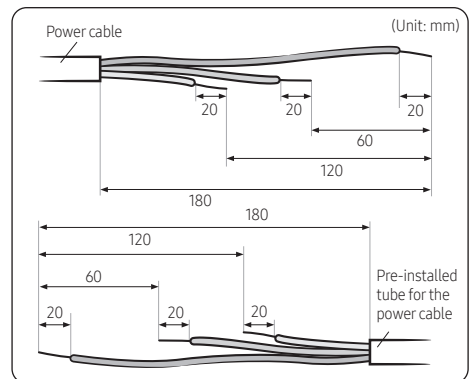

⚠ CAUTION

- For information about the power cable specifications for indoor and outdoor units, refer to the installation manual.
 - After peeling off cable wires from the pre-installed tube, insert a contraction tube.
- 3 Insert both sides of core wire of the power cable into the connection sleeve.
- Method 1:** Push the core wire into the sleeve from both sides.
 - Method 2:** Twist the wire cores together and push it into the sleeve.

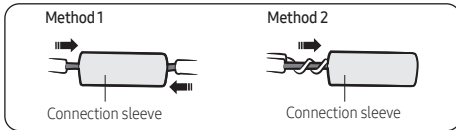

⚠ CAUTION

- If cable wires are connected without using connecting sleeves, their contact area becomes reduced, or corrosion develops on the outer surfaces of the wires (copper wires) over a long time. This may cause an increase of resistance (reduction of passing current) and consequently may result in a fire.
- 4 Using a crimping tool, compress the two points and flip it over and compress another two points in the same location.
- The compression dimension should be 8.0.

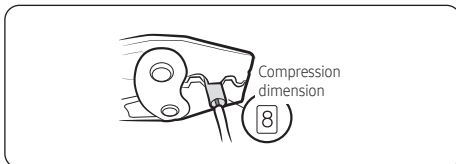

- After compressing it, pull both sides of the wire to make sure it is firmly pressed.

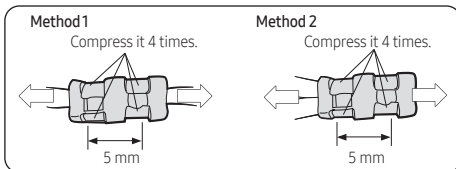

- 5 Apply heat to the contraction tube to contract it.

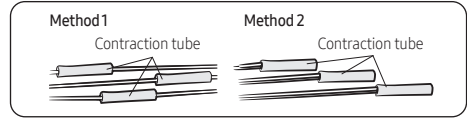

- 6 Wrap it with the insulation tape twice or more and position your contraction tube in the middle of the insulation tape.

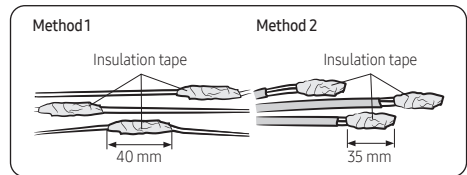

- 7 After tube contraction work is completed, wrap it with the insulation tape to finish.
Three or more layers of insulation are required.

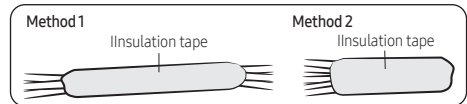

⚠ CAUTION

- Make sure that the connection parts are not exposed to outside.
- Be sure to use insulation tape and a contraction tube made of approved reinforced insulating materials that have the same level of withstand voltage with the power cable. (Comply with the local regulations on extensions.)

⚠ WARNING

- In case of extending the electric wire, please DO NOT use a round-shaped Pressing socket.
 - Incomplete wire connections can cause electric shock or a fire.

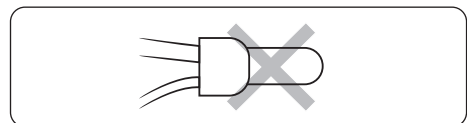

Installation Procedure

Step 11 Checking the earthing

If the power distribution circuit does not have an earthing or the earthing does not comply with specifications, an earthing electrode must be installed. The corresponding accessories are not supplied with the air conditioner.

- 1 Select an earthing electrode that complies with the specifications given in the illustration.
- 2 Connect the flexible hose to the flexible hose port.
 - In damp hard soil rather than loose sandy or gravel soil that has a higher earthing resistance.
 - Away from underground structures or facilities, such as gas pipes, water pipes, telephone lines and underground cables.
 - At least two metres away from a lightning conductor earthing electrode and its cable.

NOTE

- The earthing wire for the telephone line cannot be used to ground the air conditioner.

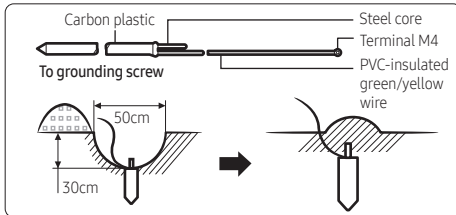

- 3 Finish wrapping insulating tape around the rest of the pipes leading to the outdoor unit.
- 4 Install a green/yellow coloured earthing wire:
 - If the earthing wire is too short, connect an extension lead in a mechanical way and wrap it with insulating tape (do not bury the connection).
 - Secure the earthing wire in position with staples.

NOTE

- If the earthing electrode is installed in an area with heavy traffic, its wire must be connected securely.
- 5 Carefully check the installation by measuring the earthing resistance with an earth resistance tester. If the resistance is above the required level, drive the electrode deeper into the ground or increase the number of earthing electrodes.
 - 6 Connect the earthing wire to the electrical component box inside of the outdoor unit.

Step 12 Performing gas leakage test

Use nitrogen gas at a pressure range between 0.2 and 4.1 MPa when testing the gas leakage. If you apply pressure at over 4.1 MPa, the refrigerant pipes may be damaged.

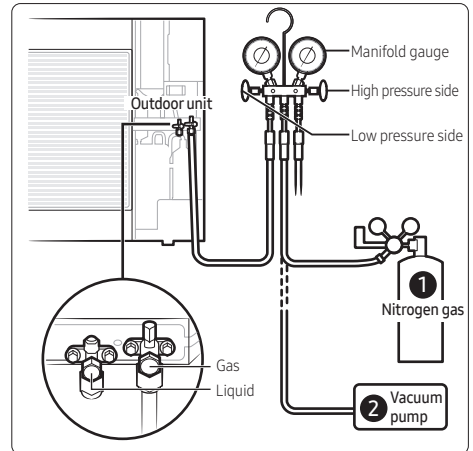

- 1 Connect the charging hose of low pressure side of manifold gauge to the packed valve having a service port as shown at the figure.

NOTE

- The designs and shape are subject to change according to the model.
- 2 Open the valve of the low pressure side (A) of the manifold gauge anticlockwise.
 - 3 Connect the manifold gauge to the nitrogen gas.
 - 4 Apply nitrogen gas.
 - 5 Check the change of pressure with a pressure regulator.
 - 6 Check the gas leakage at the connection part or brazed part by using soap water.
 - 7 Open the manifold gauge to discharge nitrogen.

Step13 Evacuating the air

- 1 Connect the manifold gauge to a vacuum pump.
- 2 Purge the air from the system using the vacuum pump for about 30 minutes.
 - Make sure that pressure gauge shows -0.1006 Mpa after about 30 minutes.
 - Use a vacuum pump that is at least 140 l/min in capacity.
 - Make sure that vacuuming timing is longer when the piping gets longer.
 - Pressure will not drop even after 5 minutes of vacuuming when there is moisture within the pipe. In this case, apply nitrogen gas again, and then purge the air again.

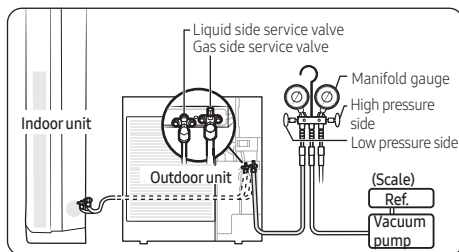

Open the manifold gauge valve connected to the liquid service valve and add refrigerant to reach the fixed quantity noting the scale.

NOTE

- If you cannot add refrigerant when the operation of the outdoor unit is stopped, open the gas and liquid service valves and add remaining refrigerant by pressing the cooling trial operation button.
- After charging, completely open the spindles of the both the gas and liquid side service valves by rotating them anti-clockwise. (Do not press them further if the spindle hits the stopper.)
- Fasten the caps of the service valves for the gas and liquid pipes including the cap nut of the charging port.
 - There may be slight refrigerant leakage when you open the spindle with a wrench. This is not a failure of the product.
 - Use a wrench that can apply the appropriate force.

Step14 Charging the refrigerant

- 1 Measure the quantity of refrigerant depending on the length of the liquid side pipe.

NOTE

- When the pipe length exceeds the standard pipe length of 5 m, charge refrigerant according to the increased length. Do not charge refrigerant by assuming the quantity through the pressure gauge. When the pipe length is shorter than the standard, you do not need to charge refrigerant.

Model name	Refrigerant amount	
	Standard (less 5m)	Additional (over 5m)
	g	g/m
AC030BXPDKC	2000	10
AC036BXPDKC	2600	30
AC048BXPDKC AC048BXPDNC	2900	30
AC054BXPDNC	3800	30

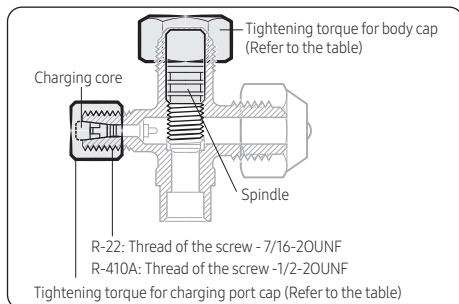

Installation Procedure

Outer diameter (mm)	Tightening torque	
	Body cap (N•m)	Charging port cap (N•m)
ø 6.35	20 to 25	10 to 12
ø 9.52	20 to 25	
ø 12.70	25 to 30	
ø 15.88	30 to 35	
Over ø 19.05	35 to 40	

(1 N•m = 10 kg•cm)

Step 15 Fixing and insulating the connection part for refrigerant pipes

⚠ CAUTION

- Before wrapping the connection part for refrigerant pipes, be sure to check whether there is gas leakage on the connection part.
- Wrap the foam insulation around the connection part as shown in the figure. This wrapping minimises condensation.

📖 NOTE

- Be extra cautious for the gas leakage from the 3-way valve's stem nuts (gas side), and from the service port cap.

Pressure table for each temperature

If extra refrigerant charging is required due to gas leakage or product relocation, see the following table.

Cooling operation

Unit: [kPa, G]

Indoor temperature (°C) (Dry bulb / Wet bulb)	Outdoor temperature (°C)		
	32/23	27/19	21/15
46	1040	850	730
35	920	750	640
21	830	690	590
7	690	540	490
-15	550	400	370

📖 NOTE

- Pressure for each temperature was measured at the gas side service valve.

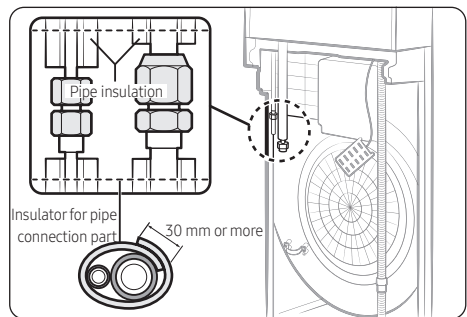
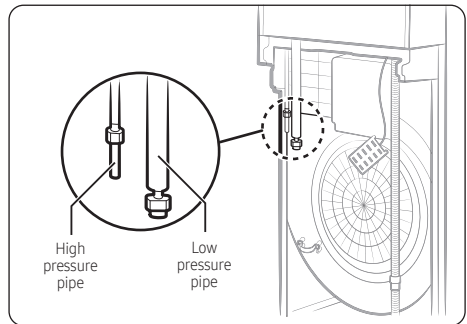

📖 NOTE

- Use polyethylene foam over 5 mm thick to insulate the connection.

- 2 Fasten the pipes with a pipe clamp and fix it with screws.

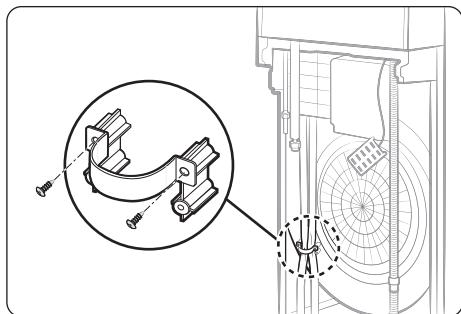

⚠ WARNING

- Remove the middle part of the pipe outlet protection rubber before inserting the pipe.

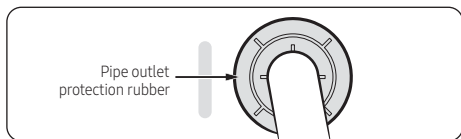

Step 16 Installing and connecting the drain hose

- 1 Wrap the drain hose with the provided insulation. This wrapping minimises condensation.

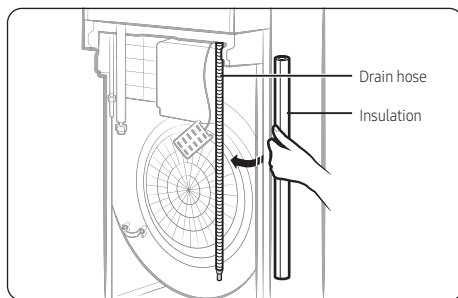

- 2 Insert the end of the drain hose to the extension drain hose to make a connection.
3 Tightly wrap the connection part with a cable tie or tape for fixing.

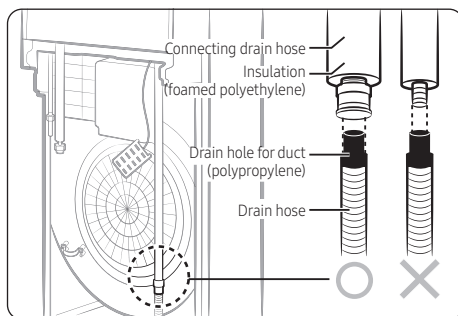

Installation Procedure

- When the hole of the drain hose on the wall is lower than that of the drain hose connection

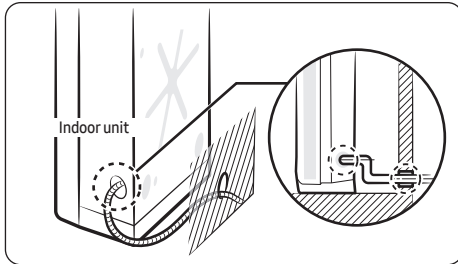

- When the hole of the drain hose on the wall is higher than that of the drain hose connection

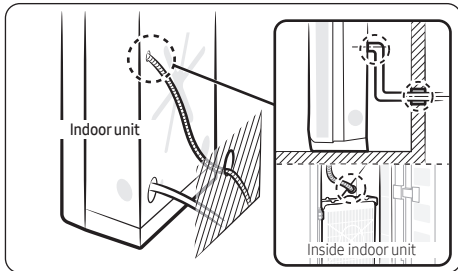

Step 17 Performing drainage test

Put the water bottle deeply into the first blade on the left of the air outlet and slowly pour water.

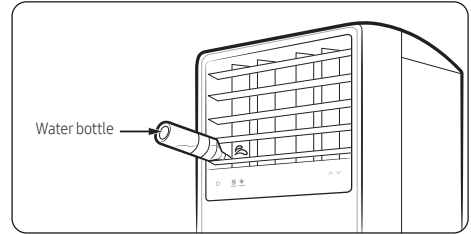

⚠ CAUTION

- Install the drain hose in a downward direction.
- Water leakage may occur when the drain hose is not firmly fixed with a cable tie or tape.
- If there is any foreign substance in the drain pan, it may clog the drain hose. Be sure to remove the foreign substance after installation.
- Do not use the drain hose connected by multiple drain hoses.
 - Water may leak from the extension connection part. Install the drain hose for each piece.
 - If its length is too short and you cannot avoid the connecting multiple drain hoses, be sure to use silicone sealant or other material for waterproofing. Do not use the insulating tape.

Step 18 Checking the earthing

Before supplying main power, use a DC 500V insulation resistance tester to measure the resistance between the power terminals (L, N) and the outdoor unit earthing. Make sure that the measurement comes to 30 MΩ.

⚠ CAUTION

- Do not test the communication terminals with the DC 500V insulation resistance tester. Failure to do so may damage the communication circuit.
- Use a common circuit tester to test the communication terminals for open or short circuit.

Step 19 Performing the final check and trial operation

- Check the power supply between the outdoor unit and the auxiliary circuit breaker.
 - 1 phase power supply: L, N
 - 3 phase power supply: R, S, T, N
- Check the indoor unit.
 - Check that you have connected the power and communication cables correctly. If the power cable and communication cables are mixed up or connected incorrectly, the PCB will be damaged.
 - Check that the thermistor sensor, drain pump/hose, and display are connected correctly.
- Press K2 on the outdoor unit PCB to run the test mode and stop.

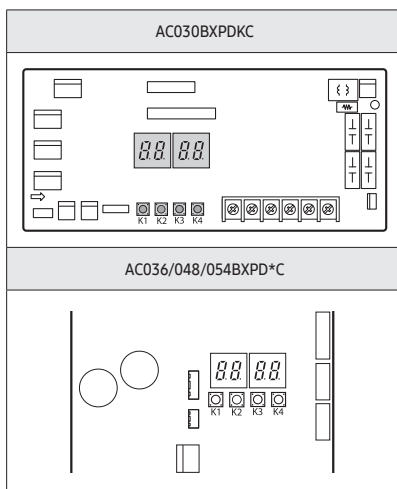

Key	Push type	Mode	Display				
			SEG1	SEG2	SEG3	SEG4	
K2	Short	1st	Cooling test mode	F	2	8	8
		2nd	Inverter check	F	4	8	8
		3rd	Pump down	F	6	8	8
		4th	Not applicable	F	8	8	8
		5th	Inverter Fault Detection (Comp#1) ¹⁾	F	A	8	8
		6th	Auto trial operation	F	C	8	8
		7th	Not applicable	F	E	8	8
		8th	End Key operation	8	8	8	8

- After 12 minutes of stationary conditions check each indoor unit air treatment:
 - Cooling mode (indoor unit check) → Inlet air temp. - Outlet air temp.: From 10°C to 12°C
- How to reset the power supply of the outdoor unit and deactivate the eco mode (standby mode):
 - Outdoor unit types A, B and C: Press the K3 button for over 1 second to reset the power supply of the outdoor unit and deactivate the eco mode (standby mode).

¹⁾ Indication on the display and action to take when an inverter fault is detected

	SEG1	SEG2	SEG3	SEG4	Action to take
Fault detection is in progress	F	1	8	8	-
OK	F	1	0	F	-
NG	F	1	A	C	PBA defect: Replace the PBA
Check	F	1	C	H	Manual inspection is required
Going into fault detection mode failed	F	1	F	1	Try fault detection again

Installation Procedure

6 View mode: When the K4 switch is pressed, you can see information about our system state, as detailed below.

K4 short push	Display contents	SEG1	SEG2	SEG3	SEG4	Unit
1	Order frequency	1	Hundreds digit	Tens digit	Units digit	Hz
2	Current frequency	2	Hundreds digit	Tens digit	Units digit	Hz
3	The number of current indoor units	3	Hundreds digit	Tens digit	Units digit	EA
4	The sensor for outdoor air intake	4	+ / -	Tens digit	Units digit	°C
5	Discharge sensor	5	Hundreds digit	Tens digit	Units digit	°C
6	Eva-Mid sensor	6	+ / -	Tens digit	Units digit	°C
7	Cond sensor	7	+ / -	Tens digit	Units digit	°C
8	Current	8	Tens digit	Units digit	The first place of decimals	A
9	Fan RPM	9	Thousands digit	Hundreds digit	Tens digit	rpm
10	Target discharge temperature	A	Hundreds digit	Tens digit	Units digit	°C
11	EEV	B	Hundreds digit	Tens digit	Units digit	step
12	The capacity sum of indoor units	C	Tens digit	Units digit	The first place of decimals	kW
13	Protective control	D	0: Cooling	Protective control 0: No Protective control 1: Freezing 2: Non-stop defrosting 3: Over-load 4: Discharge 5: Total electric current	Frequency status 0: Normal 1: Hold 2: Down 3: Up_limit 4: Down_limit	-
14	The temperature of heat radiating plate	E	Hundreds digit	Tens digit	Units digit	-
15	The number of connected indoor units	F	Hundreds digit	Tens digit	Units digit	EA

	Display contents	SEG1	SEG2	SEG3	SEG4	
K4 long push	-	Main micom version	Year (Dec)	Month (Hex)	Date (Tens digit)	Date (Units digit)
	After short push 1	Inverter micom version	Year (Dec)	Month (Hex)	Date (Tens digit)	Date (Units digit)
	After short push 2	E2P version	Year (Dec)	Month (Hex)	Date (Tens digit)	Date (Units digit)
	After short push 3	Page 1 - AUTO Page 2 - (SEG1,2 - Indoor : "A","0") (SEG3,4 - Address : ex) 00				
	After short push 4	Page 1 - MANU Page 2 - (SEG1,2 - Indoor : "A","0") (SEG3,4 - Address : ex) 00				

Long push K4 (Main micom ver.) → short push 1 more (Inv. micom ver.) → short push 1 more (E2P ver.) → short push 1 more (Automatic address) → short push 1 more (Manual address) → short push 1 more (Main micom ver.) → → Long push K4 (View mode end)

Installation Procedure

7 Setting outdoor unit option switch and address manually

a Setting the option

- Press and hold K2 to enter the option setting. (Only available when the operation is stopped)
 - If you enter the option setting, display will show the following.

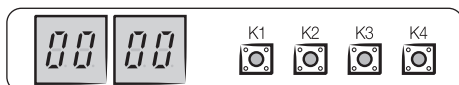

- Seg 1 and Seg 2 will display the number for selected option.
- Seg 3 and Seg 4 will display the number for set value of the selected option.
- If you have entered option setting, you can shortly press the K1 switch to adjust the value of the Seg 1, Seg 2 and select the desired option.

Example)

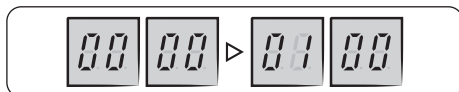

- If you have selected desired option, you can shortly press the K2 switch to adjust the value of the Seg 3, Seg 4 and change the function for the selected option.

Example)

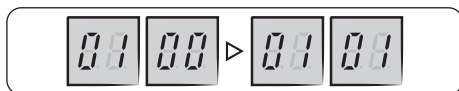

- After selecting the function for options, press and hold the K2 switch for 2 seconds. Edited value of the option will be saved when entire segments blinks and tracking mode begins.

Option item	Input unit	SEG1	SEG2	SEG3	SEG4	Function
Channel address	Main	0	0	A	U	Automatic setting (Factory default)
				00-15		Manual setting
Snow accumulation prevention control	Main	0	1	0	0	Disabled (Factory default)
				0	1	Enabled
Step for Silence mode	Main	0	2	0	0	Disabled (Factory default)
				0	1	Step1
				0	2	Step2
				0	3	Step3

Option item	Input unit	SEG1	SEG2	SEG3	SEG4	Function
Type of Silence mode	Main	0	3	0	0	Automatic Silence mode (Factory default)
				0	1	Manual Silence mode
Temperature unit	Main	0	4	0	0	Celsius (default)
				0	1	Fahrenheit
Not applicable	Main	0	5	0	0	Not applicable
				0	1	Not applicable
Current restriction rate ¹⁾	Main	0	6	0	0	100% (Factory default)
				0	1	95%
				0	2	90%
				0	3	85%
				0	4	80%
				0	5	75%
				0	6	70%
				0	7	65%
				0	8	60%
				1	0	50%
				1	1	100%
Dedicated mode for cooling/heating ²⁾	Main	0	7	0	0	Cooling / Heating operation (default)
				0	1	Cooling operation only
				0	2	Heating operation only

- ¹⁾ Current restriction rate : When restriction option is set, cooling and heating performance may decrease.
- ²⁾ AC***BXAD*C models are cooling-only models and do not support heating mode. These models operate in cooling mode only, even if "heating operation only" mode is enabled.

⚠ CAUTION

- Edited option will not be saved if you do not end the option setting as explained in above instruction.
 - While you are setting the option, you may press and hold the K1 button to reset the value to previous setting.
 - If you want to restore the setting to factory default, press and hold the K4 button while you are in the option setting mode.
 - If you press and hold the K4 button, setting will be restored to factory default but it doesn't mean that restored setting is saved. Press and hold the K2 button. When the segments shows that tracking mode is in progress, setting will be saved.

Installation Procedure

Emergency Temperature Output (ETO) function

CAUTION

- In order to deploy the ETO function, the MIM-B14, an external contact interface module, must be installed in each indoor unit.
 - The ETO is a concept of emergency operation of indoor units. If the indoor unit 1 (main indoor unit) stops because of an error, the indoor unit 2 (sub indoor unit) starts to operate.
 - Basically, the indoor unit 2 operates in the previous mode. [For the first time operation, it starts in 24 °C Auto mode.]
 - To set more detailed operation conditions for the indoor unit 2, use the S-net Pro.

Setting up the ETO

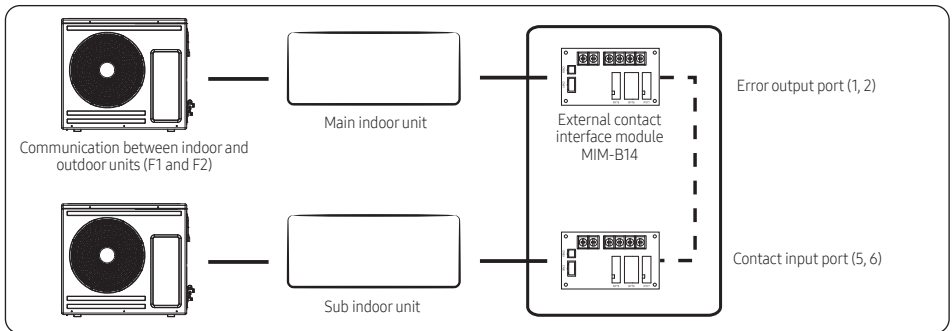

- 1 Main indoor unit
 - Disable the external contact control (Default).
 - Connect the S-net pro2 to F1 and F2.
 - Enable the ETO function and set the temperature and time.
- 2 Sub indoor unit
 - (Required) Enable the external contact control (with the installation option SEG14 - Reverse Control).
 - Connect the S-net pro2 to F1 and F2.
 - Enable the entrance control and set the mode, set temperature, and fan speed.

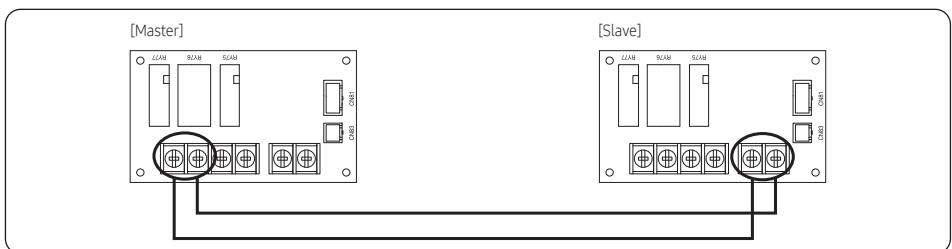

ETO operation specifications

1 Main indoor unit

- Based on the external contact control settings, the main indoor unit decides whether to generate output when an error (indoor unit stop) occurs.
- Based on the ETO settings, the main indoor unit decides whether to generate output according to the temperature and time conditions.

2 Sub indoor unit

- Based on the entrance control settings, the sub indoor unit decides the mode, set temperature, and fan speed when contact inputs are given.

Main indoor unit	Enable of ETO	Enable of external contact	Error port output
	X	X	N/A
	X	O	Output due to an error
	O	X	Output by ETO entrance conditions (temperature / time / error occurrence)
O	O	Output by ETO entrance conditions (temperature / time / error occurrence) ※ Ready to control the main contact input	

Sub indoor unit	Enable of entrance control	Enable of external contact	Operation when outputting Main
	X	X	N/A
	X	O	On with the previous operation conditions
O	O	On with the entrance control enabled	

Appendix

Troubleshooting

The table below lists the self-diagnostic routines. For some of error codes, you must contact an authorized service centre. If an error occurs during the operation, it is displayed on the outdoor unit PCB LED, both MAIN PCB and INVERTER PCB.

No.	Error Code	Meaning	Remarks
1	E108	Error due to duplicated communication address	Check on repeated indoor unit main address
2	E121	Error on room temperature sensor of indoor unit (Short or Open)	Indoor unit Room Thermistor Open/Short
3	E122	Error on EVA IN sensor of indoor unit (Short or Open)	Indoor unit EVA_IN Thermistor Open/Short
4	E123	Error on EVA OUT sensor of indoor unit (Short or Open)	Indoor unit EVA_OUT Thermistor Open/Short
5	E153	Error on float switch (2nd detection)	Indoor unit Float Switch Open/Short Drain Pump operation Check
6	E154	Indoor fan error	Check on indoor unit indoor Fan operation
7	E198	Error on thermal fuse of indoor unit (Open)	Thermal Fuse Open Check of indoor unit Terminal Block
8	E201	Communication error between the indoor unit and outdoor unit (Pre-tracking failure or when the actual number of indoor units are different from the indoor unit quantity setting on the outdoor unit) Error due to communication tracking failure after initial power is supplied (The error occurs regardless of the number of units.)	Check indoor quantity setting in outdoor
9	E202	Communication error between indoor unit and outdoor unit (When there is no response from indoor units after tracking is completed)	Check electrical connection and setting between indoor unit and outdoor unit
10	E203	Communication error between the outdoor unit and main micom (For PF #4 to #6 controllers, error will be determined from the time when the compressor is turned on.)	Check electrical connection and setting between outdoor unit MAIN PBA - INVERTER PBA
11	E221	Error on outdoor temperature sensor (Short or Open)	Check Outdoor sensor Open / Short
12	E231	Error on outdoor COND OUT sensor (Short or Open)	Check Cond-Out sensor Open / Short
13	E251	Error on discharge temperature sensor of compressor1 (Short or Open)	Check Discharge sensor Open / Short
14	E320	Error on OLP sensor (Short or Open)	Check OLP sensor Open / Short
15	E403	Compressor down due to freeze protection control	Check Outdoor Cond.
16	E404	System stop due to overload protection control	Check Comp. when it starts
17	E416	System stop due to discharge temperature	-
18	E422	Blockage detected on high pressure pipe	1. Check if the service valve is open 2. Check for refrigerant leakage (pipe connections, heat exchanger) and charge refrigerant if necessary 3. Check if there's any blockage on the refrigerant cycle (indoor unit/outdoor unit) 4. Check if additional refrigerant has been added after pipe extension
19	E425	Reverse phase or open phase	Check whether 3 phase is reversed or opened.
20	E440	Heating operation restricted at outdoor temperature over Heat_high value (default:30°C)	1. Check the range of temperature limited for heating operation 2. Check the outdoor temperature sensor

No.	Error Code	Meaning	Remarks
21	E441	Cooling operation restricted at outdoor temperature below Tcool_low value (default:0°C)	1. Check the range of temperature limited for cooling operation 2. Check the outdoor temperature sensor
22	E458	Fan speed error	FAN1 ERROR
23	E461	Error due to operation failure of inverter compressor	-
24	E462	System stop due to full current control	-
25	E463	Over current trip / PFC over current error	Check OLP sensor
26	E464	IPM Over Current(O.C)	1. Check if the service valve is open 2. Check the state of refrigerant 3. Check if connecting wire and the pipe are OK 4. Check the compressor
27	E465	Comp. Over load error	-
28	E466	DC-Link voltage under/over error	Check AC Power and DC Link Voltage
29	E467	Error due to abnormal rotation of the compressor or unconnected wire of compressor	Check Comp wire
30	E468	Error on current sensor (Short or Open)	Check Outdoor Inverter PBA.
31	E469	Error on DC-Link voltage sensor (Short or Open)	-
32	E470	Outdoor unit EEPROM Read/Write error (Option)	Check Outdoor EEPROM Data
33	E471	Outdoor unit EEPROM Read/Write error (H/W)	Check Outdoor EEPROM PBA
36	E474	Error on IPM Heat Sink sensor of inverter1 (Short or Open)	Check Outdoor Inverter PBA.
37	E475	Error on inverter fan 2	FAN2 ERROR
38	E484	PFC Overload (Over current) Error	Check Outdoor Inverter PBA.
39	E485	Error on input current sensor of inverter1 (Short or Open)	Check Outdoor EEPROM PBA
40	E500	IPM over heat error on inverter1	Check Outdoor Inverter PBA.
41	E508	Smart install is not installed	-
42	E554	Gas leak detected	Check the refrigerant
43	E556	Error due to mismatching capacity of indoor and outdoor unit	Check the indoor and outdoor unit capacity
44	E557	DPM remote controller option error	Check the indoor option code
45	E590	Inverter EEPROM Checksum error	-

QUESTIONS OR COMMENTS?

COUNTRY	CALL	OR VISIT US ONLINE AT
PHILIPPINES	1-800-10-7267864 [PLDT - Toll Free] 1-800-8-7267864 [Globe - Toll Free] 84222111 [Landline]	www.samsung.com/ph/support

